

***Evaluation of potential impacts of proposed
Florida Power and Light Company transmission power lines
on avian resources in Everglades National Park***

U.S. Department of the Interior
National Park Service
Everglades National Park
South Florida Natural Resources Center
Homestead, Florida 33030-4443
October 6, 2010

Executive Summary

The purpose of this study was to assess the risk to avian resources from the Florida Power and Light Company Turkey Point Expansion project. The construction of high voltage transmission power lines is proposed in an area referred to as the West Preferred Corridor. The specific objectives of the study were to identify risk factors that affect rates of avian electrocution and collision with transmission power lines, perform an injury and mortality risk assessment for avian resources within Everglades National Park, and describe habitat impacts that may occur related to the proposed project.

A comprehensive literature review was conducted to identify risk factors for avian injury and mortality in relation to transmission power lines. Findings indicate that power line location in relation to avian foraging, roosting and nesting sites, bird behavior, life history stage, bird morphology (form), population size, proximity to wetland habitats, and utility design features affect avian electrocution and collision rates. All of the avian injury and mortality risk factors identified in the literature review occur within the West Preferred Corridor and adjacent habitats. Although there is widespread recognition that power lines negatively impact avian species, impacts may be site specific and mitigation efforts have been shown to reduce, but not eliminate, electrocutions and collisions. Specific mitigation design features for the West Preferred Corridor project are not yet available for evaluation.

Studies on power lines and avian impacts in the Florida Everglades are limited and specific; therefore, quantitative predictions of avian injury and mortality rates that may result from implementation of the proposed Florida Power and Light power lines are difficult to make due to insufficient data. Based on our literature review, a qualitative risk assessment for avian resources in the proposed West Preferred Corridor was conducted. Risk of avian injury and mortality was evaluated for the following groups of wetland birds present in the area: raptors, wading birds, waterfowl, and passerines. Risk was defined as low, moderate, or high depending on the assessed risk to individuals, breeding colonies, and populations. We focused on threats to migratory and threatened and endangered avian species present within Everglades National Park, including the Everglade snail kite (*Rostrhamus sociabilis plumbeus*) and the wood stork (*Mycteria americana*).

The results of our avian risk assessment indicate that implementation of the proposed West Preferred Corridor presents varying degrees of risks depending on the bird group, and even the species, being evaluated. The placement of the West Preferred Corridor adjacent to colonial wading bird habitat—across major wetland systems and within anticipated foraging flight paths—places wading birds at increased risk of injury and mortality as compared to other bird groups and species. The West Preferred Corridor poses a moderate risk to wading birds in the

3B Mud East, Tamiami (Tamiami West, Tamiami East 1, and Tamiami East 2), and Grossman Ridge West colonies due to potential impacts to nesting productivity, including loss of juveniles. The endangered wood stork and other state-listed wading birds, susceptible to collisions with transmission power lines, may be at a moderate to high risk due to their limited population size, morphology, flight patterns, and the abundance of juveniles in the area.

The proposed West Preferred Corridor project may adversely impact the natural hydrology of the area due to permanent wetland filling associated with construction of the power lines and any access roads. Wetland dredging and filling in the West Preferred Corridor would result in the loss of more than 100 acres of avian habitat that are currently undeveloped wetlands within Everglades National Park. Habitat loss has been identified as a cause of decline of threatened and endangered species.

Detailed population viability analyses are recommended to further evaluate potential population-level impacts to the wood stork and other federal- and state-listed wading birds. A comprehensive risk assessment for avifauna in and around Everglades National Park is recommended in order to evaluate the entire length of the proposed Florida Power and Light Company transmission corridor in Miami-Dade County and fully assess the potential for collisions, electrocutions, and habitat loss resulting from all activities associated with construction and maintenance of the proposed project in order to understand the cumulative risks.

Restoration of the abundant wading bird colonies that defined the historic Everglades is a driving force behind Everglades restoration efforts. Many planned restoration projects focus specifically on restoring the natural hydrology of Northeast Shark River Slough with the expectation of improving wading bird habitat and species productivity. The placement of the proposed transmission power line corridor within this area would likely have adverse impacts in our ability to achieve Everglades restoration goals. The potential for interactions of the West Preferred Corridor project with the suite of ecosystem restoration projects planned for implementation within and around Everglades National Park requires evaluation.

Table of Contents

Contributing Authors	vii
Editors	vii
Acknowledgements	vii
Introduction	1
Study purpose and objectives	1
Utility structure designs and mitigation for avian impacts	1
Design of proposed Florida Power and Light transmission lines.....	4
Regulations protecting avian species	6
Methods	6
Literature Review	8
Risk factors affecting avian injury and mortality rates with power lines	8
Avian species and colonies in the proposed West Preferred Corridor and adjacent habitats.....	11
Florida avian power line studies and data.....	13
Challenges to quantifying avian impacts from the proposed West Preferred Corridor project	15
Risk Assessment	17
Impacts to avian habitat in the proposed West Preferred Corridor	17
Known avian injury and mortality risk factors in the proposed West Preferred Corridor	19
Avian risk assessment of the proposed West Preferred Corridor	22
Conclusions	28
Literature Cited	30
Figures	35
Figure 1. Location of the existing Florida Power and Light West Secondary Corridor (orange) and the proposed Florida Power and Light West Preferred Corridor (yellow).	36
Figure 2A. Conceptual drawing of the 500-kV transmission power line structure within the West Preferred Corridor.....	37
Figure 2B. Conceptual drawing of the 230-kV transmission power line structure within the West Preferred Corridor.....	38

Figure 2C. Conceptual drawing of the 230-kV transmission power line structure within the West Preferred Corridor.....	39
Figure 3A. Conceptual drawing of the two 500-kV transmission power lines and the 230-kV transmission power line structures within the West Preferred Corridor.	40
Figure 3B. Conceptual drawing of the two 500-kV transmission power lines and the 230-kV transmission power line structures within the West Preferred Corridor.	41
Figure 4A. Overhead conceptual drawing of the two 500-kV transmission power lines and the 230-kV transmission power line features within the West Preferred Corridor.	42
Figure 4B. Overhead conceptual drawing of the solitary 230-kV transmission power line features within the West Preferred Corridor.	43
Figure 5. Estimated bird group electrocution and collision susceptibility with power lines based on principal components analysis of wing size and wing proportions.	44
Figure 6. Everglade snail kite nesting locations in the West Preferred Corridor footprint during the 2010 nesting season.	45
Figure 7A. 2009 Wading bird colonies (multiple species including anhingas) in the Water Conservation Areas (WCA) and Everglades National Park (ENP).	46
Figure 7B. Wood stork colonies in the WCAs and Everglades National Park.....	47
Figure 7C. 3B Mud East, Tamiami, and Grossman Ridge West wood stork colonies and management zones.	48
Figure 7D. Average foraging radii (6.40 miles \pm 8.32 miles, mean \pm 1 standard deviation) of the 3B Mud East, Tamiami, and Grossman Ridge West colonies.	49
Figure 8. Levee-Midway Power Line study sites in Water Conservation Area-2.	50
Tables	51
Table 1. Avian species known or anticipated to occur in the proposed West Preferred Corridor Area and adjacent areas.....	52
Table 2. Numbers of wading bird nests (also includes anhingas) recorded from surveys conducted at the Tamiami colonies, Grossman Ridge West Colony, in Everglades National Park and the 3B Mud East Colony in Water Conservation Area-3B.	68
Table 3. Avian injury and mortality reported at the Levee-Midway Transmission Power Line March–July 1996 and February–July, 1997.....	70
Table 4. Avian mortality reported from Florida Power and Light transmission structures in Florida from January 1, 2005, through May 21, 2010.	71
Table 5. Avian injury and mortality risk factors that exist within the West Preferred Corridor and adjacent habitats (approximately 3-mile radius).....	72
Table 6. Distance traveled to foraging sites at the L-67 Colony in WCA-3 in 1989.....	72

Contributing Authors

Alicia LoGalbo and Mike Zimmerman

South Florida Natural Resources Center, Everglades National Park, 950 N. Krome Avenue,
Homestead, FL 33030-4443

Comments and Questions: Alicia_LoGalbo@nps.gov

Editors

David Hallac and Alice Clarke

South Florida Natural Resources Center, Everglades National Park, 950 N. Krome Avenue,
Homestead, FL 33030-4443

Acknowledgements

The authors thank Sonny Bass, Brien Culhane, Jerry Krueger, Carol Mitchell, Tim Pinion, Jimi Sadle, and Jerry Mitchell of the National Park Service for their review and thoughtful suggestions. We also wish to thank Anthony Savereno, Susan Jewell, and John Ogden, each of whom conducted a thorough review of our report and provided very constructive comments on how to improve our report. Our thanks go as well to Everglades National Park staff who played a role in the production of this report: Ellen Hardy, copy editor, and Joy Brunk and Brandon Gamble, desktop publishers. The final version of this report is much improved as a result of all of these contributions.

Introduction

Study purpose and objectives

In the 1960s, the Florida Power and Light Company purchased a strip of land in the Northeast Shark River Slough area of western Miami-Dade County, Florida. Florida Power and Light refers to this area as the West Secondary Corridor in their Site Certification Application for the proposed Turkey Point Expansion project (Florida Power and Light, 2009) (Fig. 1). The lands in this area are undeveloped wetlands without any power lines. Since the original land purchase, the U.S. Congress passed legislation authorizing the expansion of Everglades National Park. The West Secondary Corridor is located within this Everglades National Park expansion area. Florida Power and Light and the National Park Service are considering an exchange of the West Secondary Corridor for another 6.5-mile strip of land located along the eastern boundary of Everglades National Park as described in the Omnibus Public Land Management Act of 2009. Florida Power and Light refers to this area as the West Preferred Corridor (Florida Power and Light, 2009) (Fig. 1). Other sections of the West Preferred Corridor are located north of Everglades National Park (Fig. 1). Florida Power and Light proposes to construct two 500-kV transmission power lines and one 230-kV transmission power line in the West Preferred Corridor. The objectives of this study were to assess the risk of injury and mortality to avian resources in Everglades National Park and to describe anticipated impacts to avian habitats from implementation of the proposed power lines in the West Preferred Corridor.

The specific objectives were to:

1. identify risk factors that affect rates of avian electrocution and collision with transmission power line structures based on a comprehensive literature review,
2. perform an injury and mortality risk assessment for avian resources within Everglades National Park that may be impacted by the proposed West Preferred Corridor, and
3. describe habitat impacts from the proposed West Preferred Corridor that affect avian resources within Everglades National Park.

Utility structure designs and mitigation for avian impacts

Electricity from power plants flows through transmission power lines to substations, distribution lines, and eventually to consumers (Public Service Commission of Wisconsin, 2010). The electric grid consists of a high-voltage transmission system and a low-voltage distribution system (Public Service Commission of Wisconsin, 2010). Transmission structures are the largest, most visible power line structures and are energized with voltages greater than or equal to 60 kV, while distribution structures are energized with voltages less than 60 kV (Public

Service Commission of Wisconsin, 2010; Avian Power Line Interaction Committee, 2006). Our analysis focused on transmission structures because these are the structures that Florida Power and Light proposes to build in the West Preferred Corridor if the exchange were to occur.

In order to assess the potential hazards that transmission lines may pose to avian resources, it is necessary to understand in some detail the structures that would be constructed. Single-circuit transmission structures contain three energized wires, or wire bundles, called conductors, that carry electricity. Double-circuit transmission structures contain two sets of conductors (i.e., six conductors or conductor bundles in total) (Public Service Commission of Wisconsin, 2010). Some transmission power lines contain one or more ground wires (also commonly referred to as static wires, overhead wires, or shield wires) that protect the power line from lightning strikes by supplying an electrical connection with the earth (Avian Power Line Interaction Committee, 2006). Ground wires, typically located above the conductors, are normally smaller in diameter and less noticeable than conductors. Insulators, composed of non-conductive material (e.g., porcelain or polymer), serve to support conductors and physically separate a conductor from another conductor or structure on a transmission power line (Avian Power Line Interaction Committee, 2006). Transmission and ground wires may be erected on a series of poles, creating what are referred to as poled structures. Support wires that connect from the transmission structure to the ground are called guy wires.

Transmission and distribution power lines are estimated to electrocute tens to hundreds of thousands of birds annually in the United States (Manville, 2005). Wildlife can be exposed to electrical current on power line structures when simultaneously contacting two energized components of a structure or by simultaneously contacting an energized and a grounded component (Avian Power Line Interaction Committee, 2006). For example, a bird could be harmed if it contacts two conductors simultaneously or contacts a grounded metal transmission structure and an energized conductor simultaneously. The result of such contact can be burns, loss of body parts, or death by electrocution (Dwyer, 2004).

Isolation and insulation techniques are used to reduce avian electrocution risks on power lines. Isolation refers to providing a sufficient separation distance between energized conductors or between an energized conductor and grounded hardware (e.g., ground wires) (Avian Power Line Interaction Committee, 2006). The length and wing span dimensions of the largest bird anticipated in the area may be used as a minimum isolation distance between structures that pose electrocution hazards. Insulation is used to cover hardware (e.g., conductors) with non-conducting material when adequate separation is not possible or to retrofit existing structures (Avian Power Line Interaction Committee, 2006).

Even with adequate separation distances on utility structures, scavengers and predatory birds that may perch on power line structures, such as vultures and herons, can be electrocuted

when they expel large streams of excrement, called streamers, that span from an energized conductor to another power line structure (Avian Power Line Interaction Committee, 2006; Burnham, 1995). A flashover can occur when the fluid bird droppings short out the air gap between the structure and the conductor (Burnham, 1995). Results from a study conducted on Florida Power and Light transmission power lines indicated that streamer flashovers accounted for 14% of all Florida Power and Light power outages (447 streamer-related outages out of a total of 3,230 outages on Florida Power and Light lines during 1988–1992) and caused approximately the same number of outages as lightning and contamination (Burnham, 1995).

Placement of transmission structures in locations containing resident, migrating, and roosting avian species increases the risk of streamer contact with energized structures (Bahat, 2010). Mitigation for streamers includes installation of devices meant to discourage perching behaviors. Installation of perch-discouraging devices reduced streamer-related outages 32% on Florida Power and Light transmission power lines, but application of similar mitigation measures in other geographic locations has not been effective (Bahat, 2010; Burnham, 1995). Although mitigation measures can reduce avian electrocution risks on power lines, electrocution risks are never completely eliminated (Avian Power Line Interaction Committee, 2006; Burnham, 1995).

Another risk to avian species from transmission power lines is collision with power line structures, most often with the overhead ground wires or conductors. Approximately 175 million birds are killed annually by collisions with power transmission and distribution lines in the United States (Manville, 2005). Based on an extrapolated annual mortality rate of 261 avian mortalities per mile from a study in the Netherlands, Erickson et al. (2005) estimated an annual avian transmission power line collision rate for the United States of 130 million birds per year. Collisions with power lines can result in broken wings, necks, and bills, breast and head contusions, disembowelment, hemorrhaging from the mouth or nostrils, and mortality (Malcolm, 1982). Avian collisions with a ground wire accounted for 82% of transmission power line collisions in a study conducted along the South Carolina coast (Savereno et al., 1996) and for 93% of transmission power line collisions observed in studies conducted in the northern Great Plains (Faanes, 1987).

Burying power lines is one mitigation measure that can significantly reduce avian impacts (U.S. Fish and Wildlife Service, 2005; Bevanger, 1994; McNeil et al., 1985). Burying power lines essentially eliminates avian electrocution and collision risks for nearly all species except perhaps for burrowing and ground-nesting species. However, this mitigation measure may not be feasible due to financial and technical constraints (Bevanger, 1994). Other mitigation measures to reduce avian impacts include co-locating new transmission power lines with existing power lines and avoiding placement of power lines in sensitive geographic regions that

contain diverse and abundant assemblages of avian species susceptible to power line electrocution and collision risks (Bevanger, 1994; Faanes, 1987; McNeil et al., 1985). Power line placement in the habitat of endangered, threatened, and special status species susceptible to power line interactions should be specifically avoided (Faanes, 1987). Placement of power lines near wetlands and across known flight paths used by waterfowl, gulls, cranes, and other water birds for feeding, roosting, or nesting should be avoided because this increases avian collision risks (Faanes, 1987; McNeil et al., 1985; Malcolm, 1982).

Examples of physical mitigation features that reduce avian collision rates with existing transmission power lines include removal of ground wires and visibly marking conductors, ground wires, and guy wires. Marking devices include diverters, flags, balls, spirals or coils of wire, colored tape, or other objects placed on power line wires that are intended to increase wire visibility (U.S. Fish and Wildlife Service, 2005; Deng, 1998; Savereno et al., 1996; Bevanger, 1994). Bird flight diverters are plastic devices placed on power lines to make the wires more visible. Savereno et al. (1996) compared bird reactions and collisions rates at a transmission power line segment marked with yellow aviation spheres on the ground wire to another unmarked transmission power line segment along the South Carolina coast. Results showed that 35-40% of the bird flocks reacted with behavioral changes to both marked and unmarked lines, though fewer birds crossed between the conductors and ground wires at the marked lines (Savereno et al., 1996). A higher percentage of birds reacted to the marked power line (98%) as compared to the unmarked power line (89%) and collisions were reduced 53% at the transmission power line with the marked ground wires (Savereno et al., 1996). Another approach to mitigation is to align transmission power line wires at the same height to reduce entanglement risks to birds that may otherwise rapidly fly upwards to avoid a lower structure, such as a conductor, only to hit a higher structure, such as a ground wire (U.S. Fish and Wildlife Service, 2005; Bevanger, 1994).

Design of proposed Florida Power and Light transmission lines

Florida Power and Light proposes to construct two 500-kV transmission power lines and one 230-kV transmission power line in the West Preferred Corridor. Although design details are not fully specified in the Site Certification Application for the project, each poled 500-kV transmission power line structure is estimated to be approximately 135–150 ft high, suspend three conductors and two ground wires, and contain as many as eight supporting guy wires (Florida Power and Light, 2009) (Fig. 2A). Each poled 230-kV transmission power line structure is estimated to be approximately 80–105 ft high and suspend three conductors, one ground wire, and up to two supporting guy wires (Figs. 2B and 2C). The material composition of the poled structures is not fully defined in the Site Certification Application but is anticipated to be composed of concrete or a combination of concrete and steel (Florida Power and Light, 2009).

The poled structures will be configured such that there are two 500-kV transmission power lines (i.e., two poled structures) every 1,000 ft down the length of the West Preferred Corridor (potential configurations are shown in Figs. 3A and 3B). A 230-kV poled structure will be stationed every 500 ft down the length of the West Preferred Corridor. The proposed corridor is approximately 330 ft wide and may contain an approximate 18-ft-wide access road along the entire western length of the corridor (Fig. 4A). Recent discussions with Florida Power and Light suggest that this road may not be necessary. Additional access pads (approximately 79–170 ft long) are proposed east of the poled structures that would provide access from the structure pads to the existing L-31 North levee road (Figs. 4A and 4B). The location and final configuration of the access road(s) has not yet been determined. Wetland filling is planned within the proposed pads for the poled structures (Figs. 4A and 4B). Construction of the access roads and pads would result in the filling of more than 100 acres of wetlands within the West Preferred Corridor area that is currently located in Everglades National Park (Florida Power and Light, 2009). Culverts would be installed beneath access road(s) to help maintain overland flow.

As part of its Site Certification Application, Florida Power and Light proposed mitigation features to reduce impacts to wildlife, wetlands, water quality, hydrology, and vegetation (Florida Power and Light, 2009). The Site Certification Application states that Florida Power and Light plans to implement the Avian Protection Plan that was developed in coordination with the U.S. Fish and Wildlife Service (Florida Power and Light, 2007). The Avian Protection Plan (Florida Power and Light, 2007) provides general guidelines and avian-protective design standards that may reduce the probability of collisions and electrocutions of avian species at Florida Power and Light utility structures. The Avian Protection Plan (Florida Power and Light, 2007) states that bird discouraging devices, perch guards, bird platforms, and insulator shield designs are included in the standards; however, the plan does not provide any detailed information about what mitigation features would be included on specific transmission power lines, where mitigation features would be implemented, or at what frequency they would occur. The Avian Protection Plan also refers to an Environmental Assessment Checklist that would be used to help determine what design standards would be used to mitigate for electrocutions and collisions; however, the checklist is not provided in the plan (Florida Power and Light, 2007). The Avian Protection Plan states that bird flight diverters may be required for distribution lines but does not mention diverter installation on any transmission power lines (Florida Power and Light, 2007). In summary, upon review of the Florida Power and Light Site Certification Application (Florida Power and Light, 2009) and the Avian Protection Plan (Florida Power and Light, 2007), it is not clear what specific avian design mitigation features would be implemented within the proposed West Preferred Corridor.

Regulations protecting avian species

Avian species at risk of injury or mortality resulting from power line collisions and electrocutions may be protected by the Migratory Bird Treaty Act, the Bald and Golden Eagle Protection Act, the Endangered Species Act, and the State of Florida Administrative Code.

The Migratory Bird Treaty Act prohibits the “take” of migratory birds and their eggs, feathers, and nests. The definition of “take” includes any type of killing, hunting, pursuing, injuring, possessing, or transporting of a migratory bird, egg, feather, or nest. The Bald and Golden Eagle Protection Act affords similar protection specifically to bald and golden eagles. The Endangered Species Act provides protection for federally listed threatened and endangered avian species. Take as defined per the Endangered Species Act means to harass, harm, pursue, hunt, shoot, wound, kill, trap, capture, or collect, or to attempt to conduct such activities. However, unlike the Migratory Bird Treaty Act and the Bald and Golden Eagle Protection Act, the Endangered Species Act allows the U.S. Fish and Wildlife Service to allow for incidental take of threatened and endangered species for otherwise lawful activities. The Florida Administrative Code provides similar protection to avian species listed by the state of Florida as endangered threatened, or as a species of special concern.

Methods

We conducted a comprehensive literature review to identify risk factors for avian injury and mortality in relation to high voltage transmission power lines. Our review specifically sought studies in which data were collected within the Florida Everglades. However, given the limited number of such studies, studies conducted in other geographic regions were included as well. We also reviewed unpublished avian injury and mortality data collected from Florida transmission structures during the period 2005 through 2010 that were provided by Florida Power and Light (Florida Power and Light unpublished data, 2010) and reported in the U.S. Fish and Wildlife Service Bird Fatality and Injury Reporting Database (U.S. Fish and Wildlife Service unpublished data, 2010). The data provided by Florida Power and Light and the U.S. Fish and Wildlife Service were collected as part of incidental monitoring programs (e.g., collected when maintenance staff is inspecting or repairing utility structures). We also reviewed avian mortality data summarized in the Florida Power and Light (2007) Avian Protection Plan.

A comprehensive list of avian species that have the potential to occur in the West Preferred Corridor or within a three-mile radius of the West Preferred Corridor was compiled from lists of avian species previously observed in freshwater wetlands and hammocks of Everglades National Park (Everglades National Park, 2006; Loughlin et al., 1990).

Maps were generated in ArcMap™ (v. 9.3) depicting the location of the West Preferred Corridor and wading bird colonies (including anhingas (*Anhinga anhinga*) in the Everglades based on data in the 1997-2009 South Florida Wading Bird Reports (Cook and Kobza, 2009; Cook and Kobza, 2008; Cook and Herring, 2007; Cook and Call, 2006; Cook and Call, 2005; Crozier and Cook, 2004; Crozier and Gawlik, 2003; Gawlik, 2002-1997). The West Preferred Corridor was represented using the eastern and western power line boundary design details provided in the Florida Power and Light Site Certification Application (Florida Power and Light, 2009). The 3B Mud East Colony is located within Water Conservation Area (WCA)-3B outside of Everglades National Park; however, we are evaluating potential effects to this colony because wading birds nesting here may forage and roost within Everglades National Park. To describe and assess potential impacts to avian species from the proposed West Preferred Corridor utility structures, transmission power line design information provided in the Florida Power and Light Site Certification Application (Florida Power and Light, 2009) was evaluated.

Based on photographs and observations from the 2010 Everglades National Park Systematic Reconnaissance Flight wading bird surveys of the Tamiami and Grossman Ridge West colonies, we delineated the colony boundaries. We used the U.S. Department of Agriculture (2007) National Agriculture Imagery Program to represent the aerial vegetation and then manually digitized the wading bird colony locations using ArcMap™ (v. 9.3). We did not delineate the colony location of the 3B Mud East Colony because we used a previously defined boundary for this colony provided by the South Florida Water Management District (2010). For all colonies in our analysis (including the 3B Mud East Colony), we designated a primary management zone buffer of 1,000 ft surrounding the boundary of each respective colony. A 1,500-ft secondary management zone was designated surrounding the primary management zone boundary. The designated management zone delineations meet the requirements described in the Draft U.S. Fish and Wildlife Service (2006) Habitat Management Guidelines for the wood stork in the southeastern United States. We mapped a 15-mile average foraging buffer radius surrounding each individual colony boundary in ArcMap™ (v. 9.3).

Based on the literature review, we determined if risk factors identified in the literature exist in the proposed West Preferred Corridor and, when possible, ranked the degree of injury and mortality risk posed by implementation of the West Preferred Corridor to avian resources. Risk was defined as a reasonable likelihood of individual birds being injured or killed, and possibly colony-level, or population-level impacts. Specific definitions of low, moderate, and high risk are provided in the risk assessment section of this report.

Literature Review

Risk factors affecting avian injury and mortality rates with power lines

The frequency of bird collisions is thought to be location-, season-, and behavior-dependent and may be exacerbated by poor weather conditions (Deng, 1998; Crivelli et al., 1988; McNeil et al., 1985; Malcolm, 1982). A study of avian collision rates with seven transmission power lines in the northern Great Plains revealed that power lines located within 1,312 ft of wetlands had higher avian collision mortality rates than those located farther from wetlands; 90% of avian collision mortality occurred at wetlands that supported large concentrations of water birds such as waterfowl, gulls, and cranes (Faanes, 1987). Approximately 81% of all avian mortalities in a study of seven transmission power line corridors in the northern Great Plains occurred during the fall migration season (Faanes, 1987).

Significant avian mortality has been reported when power lines bisect feeding, nesting, or roosting grounds, especially when located within wetlands supporting an abundance and diversity of avian species (McNeil et al., 1985; Malcolm, 1982). For example, a transmission corridor with six conductor wires, two ground wires, and multiple guy wires was constructed through a large wetland in Montana with diverse and abundant avian populations including numerous breeding waterfowl, wading birds, songbirds, raptors, and migrating shorebirds (Malcolm, 1982). More than 4,000 bird mortalities from 55 different species resulted from collisions over this 2.8-mile corridor segment during the period of May 1, 1980, through September 29, 1981 (Malcolm, 1982). Peak collision mortality occurred during times when duck species were staging for migrations, with 14 different species of ducks accounting for 44% of all collision mortalities (Malcolm, 1982). Collisions declined following the end of the breeding season during both years of this study (Malcolm, 1982). An avian botulism outbreak proliferated by rotting carcasses from the power line collisions ensued, resulting in the death of an additional 63,000 birds, primarily ducks (Malcolm, 1982). In northeastern Venezuela, McNeil et al. (1985) reported catastrophic avian collision mortality from a transmission power line aligned parallel to a distribution power line that bisected nesting, roosting, and feeding sites. Approximately 600 bird skulls, carcasses, and injured birds from 10 species were reported from a one-day systematic carcass survey conducted on a 1.7-mile stretch between and below the transmission and distribution power lines on February 27, 1983 (McNeil et al., 1985). The north side of the lagoon supported a colony of breeding brown pelicans (*Pelecanus occidentalis*) and non-breeding neotropical cormorants (*Phalacrocorax olivaceus*) (McNeil et al., 1985).

McNeil et al. (1985) reported that avian mortalities from power line collisions were more related to species composition, behavioral patterns, flight characteristics (including flight direction), and local features than to species abundance. For example, higher collision rates

were reported for brown pelicans and black-crowned night herons (*Nycticorax nycticorax*) that frequently crossed the power lines as compared to other species (McNeil et al., 1985). During their survey, they observed two cormorants and one pelican collide with the transmission line as they flew between the breeding and resting sites of the lagoon toward feeding sites along the shoreline (McNeil et al., 1985). Observations of avian flight altitudes indicated that avian collision mortalities were mainly attributed to the transmission power line (minimum to maximum heights of wires above the lagoon were approximately 32.8–52.5 ft for the lower conductors, 49.2–68.6 ft for the upper conductors, and 55.8–75.4 ft for the ground wire) and that avian collisions with the generally lower distribution power line (minimum to maximum heights of the wires above the lagoon were approximately 29.5–34.4 ft and 34.4–39.4 ft) were nearly insignificant (McNeil et al., 1985).

Avian behavior affected by life history stage may also influence avian collision rates with power lines. Juvenile Dalmatian pelicans (*Pelecanus crispus*) collided with power lines at much higher rates than adults did during inclement weather conditions, indicating that poor flying ability and weather significantly affect avian power line collision rates (Crivelli et al., 1988). Nearly 75% of the avian collision injuries and fresh mortalities reported by McNeil et al. (1985) at distribution and transmission power lines in Venezuela were juvenile brown pelicans. Schaub and Pradel (2004) estimated a higher collision mortality rate in white stork (*Ciconia ciconia*) juveniles compared to adults. In a study conducted in Arizona, Harris' hawk (*Parabuteo unicinctus*) electrocutions occurred at distribution power line poles within 984 ft of nests, and juveniles accounted for 61% of electrocutions (Dwyer, 2004).

Time of flight and weather patterns are also thought to affect avian collision rates with transmission power lines. McNeil et al. (1985) reported that collisions with distribution and transmission power lines mainly occurred at dawn and dusk. Nocturnally foraging wading birds, including wood storks and black-crowned night herons, reacted less frequently to avoid a transmission power line at night, suggesting that power lines may pose a greater collision threat at night and during inclement weather conditions (Deng and Frederick, 2001). Dalmatian pelicans fly to feeding grounds at dusk and dawn during poor visibility conditions, which may have increased their collision risk with power lines (Crivelli et al., 1988).

Species-specific characteristics such as morphology and flight characteristics may also contribute to power line electrocution and collision risks. In general, highly maneuverable species, such as many birds of prey, are at lower risk of collision with power lines than less maneuverable species such as ducks (Janss, 2000). However, there are confirmed accounts of maneuverable flyers, such as northern harriers (*Circus cyaneus*) colliding with transmission power lines (Malcolm, 1982). Although the morphology of most passerine species (songbirds in the order Passeriformes) does not place these birds at high risk of electrocution or collision

with transmission power lines, there are confirmed accounts of passerine mortalities from collisions with transmission power line structures (Deng, 1998; Faanes, 1987; Malcolm, 1982). Though maneuverable avian species are at some risk of colliding with transmission power lines, their collision rate may be less than that of avian species with high wing loading (i.e., those with a heavy body weight and short wings) (Bevanger, 1998; Malcolm, 1982).

Weight, wing structure, total length, and tail length have been used to categorize avian species prone to collision risks, species prone to electrocution risks, and species susceptible to both risks (Janss, 2000; Bevanger, 1998). Results of a principal components analysis of wing morphology and derived size and wing proportions were used to categorize bird groups into those most at risk of power line electrocution and/or collision (Fig. 5) (Bevanger, 1998). The analysis was validated with results from 16 international avian power line studies (Bevanger, 1998). A subsequent study using a similar technique described how weight, wing length, total length, and tail length were used to classify 86.6% of avian species into categories defined as species with a high collision risk, species with a high electrocution risk, and species susceptible to both risks (Janss, 2000).

Some “thermal soarer” species that exhibit large, broad wings with a decreased wing loading are susceptible to electrocutions and collisions with power lines (Bevanger, 1998). Examples of such species include Ciconiiformes species (herons, storks, egrets, and ibises) and Pelecaniformes (pelicans) species (Bevanger, 1998). Savereno et al. (1996) reported from direct observation of collisions and carcass recoveries that wading birds are at higher risk of transmission power line mortality than other types of migratory birds. Visual observations of bird interactions with power lines in the Everglades indicate that multiple species of egrets may collide with transmission power lines due to their relatively low flight patterns (Deng, 1998).

Even if power-line-induced mortality rates appear low compared to other types of natural mortality, impacts may be substantial for threatened and endangered species or small populations (Janss and Ferrer, 1998; Faanes, 1987; McNeil et al., 1985). Power line collision mortalities have accounted for as much as 39% of mortality within the two remaining populations of endangered fledged whooping cranes (*Grus americana*) (Brown et al., 1987 cited in Deng, 1998). Power line mortality was shown to negatively impact a white stork population in Switzerland as one in four juveniles and one in 17 adults die each year from power line collisions (Schaub and Pradel, 2004). Mortality from power line collisions at wintering grounds of the endangered Dalmatian pelican decreased the number of breeding pairs by an estimated 3.5% and contributed to the lack of population recovery (Crivelli et al., 1988). This was considered such a threat that the power lines were eventually dismantled (Crivelli et al., 1988).

In summary, potential avian impacts from power lines are influenced by multiple and sometimes interrelated factors, some of which are not fully understood. Power line location

has been shown to affect avian mortality rates with higher mortality in locations closest to wetlands and locations between key foraging and other foraging, nesting, and roosting sites. Nocturnal and crepuscular (species active at dusk and dawn) avian species may be especially vulnerable to power line collisions when darkness and inclement weather affect visibility. Avian behavior and life history stage have been shown to significantly affect avian impacts with power lines, with juveniles being especially susceptible to power line collisions. Bird form and flight behavior affect avian electrocutions and collisions with power lines, with some species, such as wading birds, being vulnerable to both types of risks. Time of year and weather are also known to affect avian collision rates with higher impacts occurring during the breeding season and during inclement weather conditions. The effects of power lines on avian populations are not fully understood due to the limited number of monitoring programs, but mortality resulting from transmission power lines may significantly affect endangered, threatened, or other small avian populations.

Avian species and colonies in the proposed West Preferred Corridor and adjacent habitats

A diverse assemblage of avian species has the potential to occur, breed, and migrate within or across habitats adjacent to the proposed West Preferred Corridor (Table 1). We define adjacent habitats as those located within a three-mile radius of the West Preferred Corridor. A three-mile radius was conservatively selected because a study following bird flight showed that wood storks nesting approximately three miles from the West Preferred Corridor at the Tamiami West Colony fly across the West Preferred Corridor (Herring and Gawlik, 2007). Species included in our assessment are those that inhabit freshwater marshes, including tree islands that exist adjacent to the West Preferred Corridor in Northeast Shark River Slough. Species not included are those that predominantly inhabit the mangrove forests, Florida Bay, other estuarine bays, and lakes within Everglades National Park, unless these species are anticipated to forage in or migrate through the West Preferred Corridor or adjacent habitats. A number of federal- and state-listed species, migratory and resident species, and species reported as injured or killed by power lines in Florida use habitats in the West Preferred Corridor and adjacent habitats (Table 1).

The federal- and state-listed endangered Everglade snail kite (*Rostrhamus sociabilis plumbeus*) and wood stork are known to forage, roost, and breed within Shark River Slough and WCA-3B, located north of the park. Everglade snail kite nesting behavior was reported during the 2010-nesting season within the footprint of the Florida Power and Light West Preferred Corridor (Fig. 6). A number of Everglades wading bird colonies present in 2009 (multiple species, including anhingas) and wood stork colonies, specifically, are located near the West Preferred Corridor (Figs. 7A, 7B, 7C, and 7D).

Two wood stork colonies, the 3B Mud East colony in WCA-3B and the Tamiami East 1 colony in Everglades National Park, are located less than 1 mile west of the proposed West Preferred Corridor (Figs. 7A, 7B, 7C, and 7D). The Tamiami West and the Tamiami East 2 wading bird colonies, which are also wood stork nesting colonies, are located less than 3 miles west of the proposed West Preferred Corridor (Figs. 7A, 7B, 7C, and 7D). Another colony containing wood storks, the Grossman Ridge West Colony, is located less than 10 miles away from the proposed West Preferred Corridor (Figs. 7A, 7B, 7C, and 7D). Nesting has occurred in these colonies over the past thirteen years (Table 2).

Monthly wading bird abundance data, collected from December 2008 through May 2009, range from a minimum of 1,252 birds in May to a maximum of 21,801 in March within Northeast Shark River Slough, Everglades National Park (Cook and Kobza, 2009). In 6 out of the last 13 years (1997-2009), the Tamiami West colony contained more nesting wood storks than observed in WCA-1, WCA-2, and WCA-3 combined (data sources: Cook and Kobza, 2009; Cook and Kobza, 2008; Cook and Herring, 2007; Cook and Call, 2006; Cook and Call, 2005; Crozier and Cook, 2004; Crozier and Gawlik, 2003; Gawlik, 2002-1997). State-designated Species of Special Concern known to nest within the 3B Mud East Colony, the Tamiami colonies, and the Grossman Ridge Colony include snowy egrets (*Egretta thula*), little blue herons (*Egretta caerulea*), tricolored herons (*Egretta tricolor*), and white ibis (*Eudocimus albus*) (Table 2).

Other species of management concern, including those with federal or state protection, sometimes occur in the area, including the white-crowned pigeon (*Patagioenas leucocephala*), the southeastern American kestrel (*Falco sparverius paulus*), the infrequently observed Florida sandhill crane (*Grus canadensis pratensis*) and crested caracara (*Caracara cheriway*), and more than 30 other species of concern (Table 1). The relative frequency of occurrence of avian species based on previous observations is summarized in Table 1.

More than 40 bird species without special status are anticipated to nest within the West Preferred Corridor or adjacent habitats (Table 1). Other wading bird species that are not federal- or state-listed species that nest within the 3B Mud East, Tamiami, and Grossman Ridge West colonies include great egrets (*Ardea alba*), great blue herons (*Ardea herodias*), black-crowned night herons, cattle egrets (*Bubulcus ibis*), anhingas, and yellow-crowned night herons (*Nyctanassa violacea*) (Table 2).

Everglades National Park is located within the Atlantic Flyway, one of the main migratory routes for birds that breed in temperate North America and winter in the Caribbean and South America (U.S. Fish and Wildlife Service, 1999). Some neotropical migrants are designated as migratory birds of management concern in the south Florida ecosystem (U.S. Fish and Wildlife Service, 1999) and more than 20 of these are anticipated to occur within the West Preferred Corridor and adjacent habitats (Table 1). For example, the bobolink (*Dolichonyx oryzivorus*)

migrates through Everglades National Park as it flies from its breeding grounds in Canada and the northern Great Plains to its wintering habitat in South America (Everglades National Park, 2006; U.S. Fish and Wildlife Service, 1999). Species of warblers (e.g., the blackpoll warbler, *Dendroica striata*), tanagers (*Piranga spp.*), chimney swifts (*Chaetura pelagica*), tree swallows (*Tachycineta bicolor*), nighthawks (*Chordeiles spp.*), and blue-winged teals (*Anas discors*) migrate through Everglades National Park (Everglades National Park, 2006; U.S. Fish and Wildlife Service, 1999). Because of Everglades National Park's unique subtropical environment and geographic location near Cuba and the West Indies, tropical Caribbean species rarely reported in other regions of North America such as the smooth-billed ani (*Crotophaga ani*), white crowned pigeon, and black-whiskered vireo (*Vireo altiloquus*) sometimes occur in Everglades National Park (Everglades National Park, 2006; U.S. Fish and Wildlife Service, 1999).

Florida avian power line studies and data

Avian collisions and the effectiveness of an avian power line mitigation feature (visual diverter device) were studied at the Levee-Midway Transmission Power Line in WCA-2A and WCA-2B of the Florida Everglades during 1996–1997 (Fig. 8) (Deng, 1998). This transmission power line is located approximately 30 miles north of the Florida Power and Light West Preferred Corridor and within habitat that also supports a diverse array of nesting wading birds and migratory bird species (Fig. 8). Locations of wading bird colonies near Deng's (1998) study area are shown on Figure 8. Deng (1998) conducted the study at a single-circuit (with three conductor wires) 550-kV transmission power line with 98.4-ft supporting H-frames, no guy wires, and two ground wires. Visual and radar monitoring (nocturnal studies only) were conducted simultaneously at two 1,214-ft segments situated at northern, central, and southern points on the power line (Fig. 8). The northern study site did not contain marked ground wires while the central and southern study sites contained ground wires marked with flight diverter devices. Power line collision observations were limited to wetland birds within the Ardeidae, Ciconiidae, Threskiornithidae, Aramidae, and Charadriidae families (Deng, 1998). Deng's study (1998) focused on visual observations of avian collisions with the transmission power line; however, bird carcasses observed under the power line were also noted. No systematic searching was conducted for carcasses below the power lines (Deng, 1998).

More than 41,000 birds were recorded to have crossed the Levee-Midway Power Line in 15,964 flocks of 56 species during 916 hours of daytime observations conducted in 1996 (from March to July) and in 1997 (from February through July) (Deng, 1998). Deng (1998) reported an avian power line collision rate of only 0.0048% at all study sites combined and a 0.0043% collision rate for the unmitigated northern site without the flight diverters. During daytime observations, a snowy egret and a cattle egret collided with the ground wire of the power line within WCA-2B and neither appeared injured from the collision. During 129 hours of nighttime

observations at the northern and central sections, no birds were observed to collide with the power line and nocturnal flights were recorded at higher altitudes than those recorded during the day (Deng, 1998). In 1996, seven birds, including two wood storks, were reported as injured or dead underneath or adjacent to the Levee-Midway Power Line (Table 3).

All of the avian injuries and mortalities were attributed to the transmission power line with the exception of one of the wood stork mortalities that was questionable and was likely caused by either a power line collision or a vehicle collision (Deng, 1998). Additionally, Deng (1998) stated that the Florida Fish and Wildlife Conservation Commission reported significant mortality, 170 dead birds per year, of great blue herons and wood storks from collisions with another power line adjacent to the Miami Canal in WCA-3A. However, Deng (1998) did not provide a detailed description of the study methods nor the Miami Canal utility design features. The results of Deng's (1998) study indicate that marking ground wires on transmission power lines may be a viable mitigation measure to reduce impacts because birds flew higher in marked power line segments than in unmarked power line segments (Deng, 1998).

A total of 41 avian species, including birds of prey, swimming birds, seabirds, perching birds, and waterfowl have been reported as injured or killed as a result of electrocutions or collisions with utility structures in Florida (data sources as reported and cited in Florida Power and Light, 2007). More than 10 of these species are federal- or state-listed or other special status species (Table 1). Florida Power and Light maintenance staff voluntarily report avian electrocutions and collisions at Florida Power and Light utilities throughout Florida using visual observations during regular maintenance activities and during responses to power outages (Florida Power and Light personal communication, 2010). A total of five mortalities from electrocutions with transmission power lines were reported from January 1, 2005 through May 21, 2010, and a total of 14 avian mortalities from transmission power line collisions were reported from January 1, 2005 through May 21, 2010 (Table 4).

The U.S. Fish and Wildlife Service Bird Fatality and Injury Reporting Database also includes incidental avian injury-mortality data collected from transmission power lines in Florida. Review of the U.S. Fish and Wildlife Service Bird Fatality and Injury Reporting Database for the period of January 9, 2006, through April 10, 2010, revealed an additional four bird injuries and mortalities from transmission power lines in Florida to those reported in the Florida Power and Light reports (U.S. Fish and Wildlife Service unpublished data, 2010). One vulture was reported as killed by electrocution, one brown pelican and one osprey (*Pandion haliaetus*) were reported as injured from collisions, and one dead wood stork was reported within 20 ft of a transmission power line (U.S. Fish and Wildlife Service unpublished data, 2010).

Spalding and Forrester (1991) studied causes of Ciconiiformes mortality, including human-related causes, starvation, predation, and disease, in 61 colonies in Florida during 1987–1991.

A dataset containing 2,453 bird mortalities from 15 species was compiled by performing site visits to wading bird colonies (approximately every 3–6 days) and collecting carcasses within colonies, along nearby roadsides, and from rehabilitation centers (Spalding and Forrester, 1991). They also evaluated great white heron mortality data reported from a radio transmitter study conducted by the National Audubon Society in Florida. Power lines and vehicular collisions were reported as the largest causes of mortality in juvenile and adult Ciconiiformes species including great blue and great white herons, great egrets, roseate spoonbills (*Platalea ajaja*), and wood storks (Spalding and Forrester, 1991). Great blue and great white herons were reported as the Ciconiiformes species most frequently killed by power lines (Spalding and Forrester, 1991). Carcass examination and necropsy indicated that most Ciconiiformes mortalities reported at roadsides resulted from birds injured by power lines that then fell or wandered into the road (Spalding and Forrester, 1991). Results of the radio transmitter study revealed that five out of 31 juvenile great white herons and one of eight adults were killed by power lines (Spalding and Forrester, 1991). Spalding and Forrester (1991) reported that mortality from power lines was a significant mortality factor accountable for 31% of juvenile mortality and 18% of adult Ciconiiformes mortality.

Impacts to avian species and potentially to avian populations from power lines may be underestimated and largely unnoticed due to the lack of dedicated monitoring efforts (Manville, 2009; Manville, 2005). Survey biases, from scavenger activity and carcass detection error, may also lead to underestimations. For example, it was estimated that avian mortality reported by Malcolm (1982) may have been underestimated by as much as a factor of two due to scavenger removal of carcasses.

Challenges to quantifying avian impacts from the proposed West Preferred Corridor project

Only a few, limited studies of the impact of transmission power lines on avian resources within the Florida Everglades have been conducted. Florida Power and Light reports only five electrocutions and 14 avian collision mortalities from transmission power lines throughout Florida from January 1, 2005 through May 21, 2010 (Florida Power and Light unpublished data, 2010). These data cannot be interpreted as an accurate quantitative estimate of avian collision rates throughout Florida because they were generated from incidental reporting by utility monitoring staff and not from dedicated monitoring efforts to estimate avian mortality rates. Such an effort would require more thorough sampling, such as methodical searches for carcasses across power line segments over designated time periods and the inclusion of scavenger bias and carcass detection correction factors. Thus, based on the current reporting method, these avian collision and electrocution rates are likely underestimated.

Deng (1998) provided relevant information on avian collision rates with transmission power lines in the Everglades; however, the study was conducted over a short duration and in a limited area. Deng's study (1998) may have underestimated nocturnal avian collisions because birds could not be observed on the darkest nights and on nights with inclement weather. These conditions are when the highest collision rates with power lines are anticipated. Deng (1998) also did not include all avian groups and the study did not take place over all months of the year. For example, impacts to migrant species could not be fully evaluated because the study was not conducted during the fall and all winter months. Systematic searches for carcasses were not incorporated into the Deng (1998) study, so limited sample size may have underestimated avian collision rates across the observed power line segments. Deng (1998) also did not include a carcass detection factor, which likely further underestimated mortality rates.

The direct applicability of the avian collision rates found by Deng (1998) is limited because the power line design was significantly different from the design of the power lines proposed for the West Preferred Corridor. The proposed West Preferred Corridor, with nine conductor bundles (estimated total of five ground wires) and guyed pole structures (as many as eight guy wires per pole), is likely to pose greater avian collision and electrocution risks as compared to the single-circuit power line (total two ground wires and three conductors) lacking guy wires in the Deng (1998) study. Florida Fish and Wildlife Conservation Commission data collected at a Miami Canal power line indicated 170 deaths of wood storks and great blue herons per year from power line collisions, a significantly higher rate than that reported by Deng (1998). However, the avian mortality reported from the Miami Canal power line collisions was from a distribution power line (Florida Power and Light personal communication, 2010); the results are not directly comparable to avian impacts anticipated with implementation of the West Preferred Corridor transmission power lines.

Spalding and Forrester (1991) reported significant avian collision mortality rates for Ciconiiformes species in Everglades colonies, indicating that power line collisions are the single largest cause of Ciconiiformes mortality in adults and juveniles. However, Spalding and Forrester (1991) did not describe the type of power line nor power line design details; therefore, it is not certain if their results are directly comparable to avian impacts that may occur with implementation of the West Preferred Corridor power lines. The amount of mortality attributed to various causes may be affected by sampling bias in the study; potential sampling biases included overestimations of vehicle-related trauma due to roadside sampling method and underestimations of predation rates. The study did not assess scavenger carcass removal rates or include a carcass detection correction factor, so mortality rates from power lines may have been underestimated.

Because only a few, limited studies of the impact of transmission power lines on avian resources within the Florida Everglades have been conducted, it is not possible to quantify the level of avian impacts that would result from implementation of the proposed West Preferred Corridor transmission lines. However, all of the known studies of power lines indicated some degree of adverse impact. Therefore, it is likely that the proposed power lines will adversely affect multiple avian species in the area and perhaps especially pose a risk to the endangered wood stork and other wading birds nesting and foraging nearby. Wading birds nesting within the 3B Mud East, the Tamiami, and the Grossman Ridge West colonies would be at highest risk due to their proximity to, and anticipated flight patterns across, the proposed West Preferred Corridor.

Risk Assessment

Impacts to avian habitat in the proposed West Preferred Corridor

Though our study focused on the potential for increased injury and mortality to avian resources from electrocutions and collisions with the proposed transmission line structures, we also assessed direct impacts to avian habitats resulting from implementation of the West Preferred Corridor. Based on the information provided in the Site Certification Application (Florida Power and Light, 2009), the construction of the proposed transmission line structures in the West Preferred Corridor would result in the filling of more than 100 acres of habitat within the potential exchange area. This area includes wood stork and Everglade snail kite foraging habitat, as well as Everglade snail kite nesting habitat. Loss of foraging and nesting habitat is a significant cause of wood stork and Everglade snail kite declines (Martin, 2007). The breeding wood stork population in the southeastern United States is finally beginning to recover (Cook and Kobza, 2009), but any increased mortality is a cause for concern for this population.

The U.S. Fish and Wildlife Service has developed protective management guidelines for wood stork foraging, roosting, and nesting sites (U.S. Fish and Wildlife Service, 2006). The guidelines describe a primary management zone that surrounds and includes the nesting colony and a secondary management zone that surrounds the primary management zone. The primary and secondary management zones are intended to protect an active wood stork colony by placing restrictions on certain human activities, such as construction activities, during the active wood stork nesting season. The draft Habitat Management Guidelines for the wood stork in the southeastern United States developed by the U.S. Fish and Wildlife Service (2006) stipulate the following:

- Restrict the placement of power lines and other towers (less than or equal to 200 ft) within one mile of a colony.
- Avoid construction of tall towers (with guy wires) and/or power lines within one mile of roosting sites or foraging sites.
- Protect foraging sites within approximately a 19-mile radius of an active colony. Avoid impacts to foraging sites during the non-breeding season.
- Restrict alterations to the natural hydrology in the secondary management zone that may impact colony area hydrology.
- Restrict the amount of human activity in the secondary management zone above current levels.
- Restrict any decrease in wetlands or forested areas within the secondary management zone.
- Protect the vegetative and hydrologic characteristics of roosting sites used annually by wood storks that have approximately more than 20 wood storks using the site per day.

The location of the West Preferred Corridor is not consistent with the draft U.S. Fish and Wildlife Service (2006) Habitat Management Guidelines for the wood stork in the southeastern United States. The proposed location is well within 1 mile of the Tamiami East 1 colony and the 3B Mud East colony and within key foraging areas (i.e., less than 10 miles) of the Tamiami colonies, the 3B Mud East colony, and the Grossman Ridge West colony (South Florida Water Management District, 2010; Cook and Kobza, 2009; Cook and Kobza, 2008; Cook and Herring, 2007; Cook and Call, 2006; Cook and Call, 2005; Crozier and Cook, 2004; Crozier and Gawlik, 2003; Gawlik, 2002–1997). Wetlands would be filled in the secondary management zone of the 3B Mud East Colony and the Tamiami East 1 Colony, and construction and maintenance of the power line structures and access roads would permanently increase the level of human activity in this management zone. In addition, there may be negative impacts to the natural hydrology within the secondary management zones of the Tamiami colonies and the 3B Mud East colony from permanent wetland filling associated with construction of the power lines and any access roads that may be built. In addition, wetland dredging and filling from construction in the West Preferred Corridor would result in the direct loss of more than 100 acres of habitat used by more than 200 avian species, including loss of breeding habitat for more than 50 avian species (Table 1). Wetland fill associated with construction of other segments of the corridor outside of Everglades National Park will result in additional loss of wetland habitat for avian species.

Known avian injury and mortality risk factors in the proposed West Preferred Corridor

Through the literature review we conducted, we identified multiple risk factors for avian injury and mortality resulting from contact with transmission power lines. All of the avian injury and mortality risk factors identified in the literature review occur within the West Preferred Corridor and adjacent habitats (Table 5). Here, we address each of these risk factors in relation to the proposed West Preferred Corridor and the anticipated relative abundance and diversity of avian resources present in the West Preferred Corridor and adjacent areas.

Risk Factor: Species that produce streamers. The designs in the Site Certification Application for the West Preferred Corridor project do not specify the distance between grounded guy wires and energized phase conductors and not all features are labeled (Florida Power and Light, 2009). Therefore, interpretation is required to evaluate avian electrocution risks from existing designs. There appears to be little risk of avian electrocution from direct physical contact with the single-circuit non-guyed 230-kV West Preferred Corridor power line structures. This is based on the assumptions that the structures suspending the phase conductors are non-conducting insulators and that all distances between the guy wires and phase conductors exceed 7.51 ft (the wing span of the largest birds in the West Preferred Corridor, the sandhill crane and the bald eagle) (Dunn and Alderfer, 2008). Using the same assumptions, there likewise appears to be little risk of avian electrocution from direct physical collision with the single-circuit 500-kV guyed West Preferred Corridor power line structures.

The West Preferred Corridor design details provided in the Site Certification Application (Florida Power and Light, 2009) show that there are some locations on the power line where birds could perch and be electrocuted by streamer-induced flashover mortality. For example, a bird could perch on an insulator above a conductor on a 500-kV poled structure (Fig. 2A). The species most susceptible to electrocution from streamers at the proposed West Preferred Corridor power lines are raptors and herons (Florida Power and Light unpublished data, 2010; U.S. Fish and Wildlife Service unpublished data, 2010; Bevanger, 1998; Burnham, 1995). For this reason, the presence of species prone to streamer electrocution is included as a risk factor within the proposed West Preferred Corridor avian injury and mortality risk assessment.

Risk Factor: Wetland habitats and systems. Avian mortality rates can be higher at transmission power lines located near wetland habitats (Faanes, 1987). Everglades National Park provides some of the largest contiguous wetland acreage in the United States (approximately 1.5 million acres). Because of the size and significance of the wetland habitat in Everglades National Park, this risk factor exists within the proposed West Preferred Corridor

and is applicable to all avian species with the potential to occur in the West Preferred Corridor and adjacent areas (Table 1).

Risk Factor: Power line crosses foraging, roosting, and nesting sites. There is evidence that transmission power lines located across known flight paths of foraging, roosting, and nesting sites influence avian injury and mortality rates (McNeil et al., 1985; Malcolm, 1982). Various species that utilize habitats in Everglades National Park may cross the proposed West Preferred Corridor to reach the Pennsuco Wetlands located to the northeast and other wetlands located to the east and southeast of the West Preferred Corridor. The proposed West Preferred Corridor crosses previously documented flight paths of multiple endangered species, including the wood stork and the Everglade snail kite (Herring and Gawlik, 2007; Kitchens et al., 2002). It is anticipated that colonial, nesting wading birds within the 3B Mud East, Tamiami, and Grossman Ridge colonies would frequently cross the West Preferred Corridor to reach foraging grounds. This risk factor exists within the proposed West Preferred Corridor because the corridor is within the documented flight paths of wood storks nesting within the Tamiami Colony (Herring and Gawlik, 2007) and within the average foraging radii (± 1 standard deviation) of the 3B Mud East, Tamiami, and Grossman Ridge West wood stork colonies (Fig. 7D). Although we do not have documented flight paths for all species, other wading bird species that also nest within the 3B Mud East Colony, the Tamiami, and the Grossman Ridge West colonies would also likely cross the West Preferred Corridor during foraging bouts based on their previously recorded average foraging flight distances (Bancroft et al., 1994). The frequency of other species, such as waterfowl, raptors, and passerine species, crossing the West Preferred Corridor is uncertain but reasonably likely because potential habitat occurs on either side of the West Preferred Corridor.

Risk Factor: Migratory bird route. Transmission power lines located within a known migratory flight path increases avian injury and mortality rates (Faanes, 1987; Malcolm, 1982). The proposed West Preferred Corridor is located within a major migratory route, the Atlantic Flyway (U.S. Fish and Wildlife Service, 1999). Multiple bird groups migrate into Everglades National Park and have the potential to cross the West Preferred Corridor during stopovers to other areas or to seasonally inhabit Everglades National Park. Major bird groups whose seasonal migration patterns may cross the West Preferred Corridor include some wading birds, waterfowl, raptors, and passerines. For this reason, this avian risk factor clearly exists within the proposed West Preferred Corridor and adjacent habitats.

Risk Factor: Abundance of roosting, breeding, nesting, and juvenile birds. The abundance and diversity of roosting, foraging, and breeding birds including juveniles was considered in our risk assessment of the proposed West Preferred Corridor and adjacent habitats because this factor impacts avian injury and mortality rates with transmission power line corridors (Schaub

and Pradel, 2004; Crivelli et al., 1988; Malcolm, 1982). The proposed location of the West Preferred Corridor is adjacent to multiple wading bird colonies that contain a diversity of breeding species, including the endangered wood stork and multiple state-designated species of concern (Table 1). Everglade snail kite nesting activity has been previously reported directly within the footprint of the West Preferred Corridor (Dial Cordy, 2010). In addition, 40 other bird species not listed as threatened, endangered, or special status species may nest within the proposed West Preferred Corridor and adjacent habitats (Table 1). Juveniles fledging from the breeding sites are expected to be especially vulnerable to injury and mortality from the proposed power lines because they are less experienced flyers and less maneuverable than the adults and will not be as familiar with the landscape. Based on our compilation of the species anticipated to breed within the proposed West Preferred Corridor and adjacent habitats, this risk factor exists within the West Preferred Corridor and adjacent areas.

Risk Factor: Abundance and diversity of nocturnal and crepuscular species. We included the presence of nocturnal and crepuscular avian species in our risk assessment of the proposed West Preferred Corridor because these species may be at increased risk of avian injury and mortality with power lines (Deng and Frederick, 2001; Crivelli et al., 1988). This risk may be exacerbated by poor weather conditions that can lead to an even greater reduction of visibility during nighttime conditions. A diverse and abundant assemblage of nocturnal foragers, such as wood storks, great blue herons, black-crowned night herons, and other nocturnal migrants (e.g., passerines), inhabit or cross the proposed West Preferred Corridor and adjacent habitats (Table 1). Because of the abundance and diversity of nocturnal foragers and migrants anticipated in the proposed West Preferred Corridor and adjacent habitats, this risk factor also exists within the West Preferred Corridor and adjacent areas.

Risk Factor: Morphological susceptibility to collision. Bird morphology significantly affects avian collision rates with power lines (Janss, 2000; Bevanger, 1998); thus, we considered the presence of birds with morphology prone to power line collisions as another risk factor. The bird groups with the morphology most susceptible to collisions are wading birds, cranes, and waterfowl (Malcolm, 1982). The heavy body form and short wings of these species make them less maneuverable than some other species such as raptors and passerines. Because of the abundance of wading birds and presence of some waterfowl species in the proposed West Preferred Corridor and adjacent habitats, this risk factor exists within the West Preferred Corridor and adjacent areas.

Risk Factor: Threatened and endangered species. The presence of endangered, threatened, and special status avian species is significant to a power line risk assessment because some these populations may not be able to maintain or increase their population size when faced with increased mortality rates (Janss and Ferrer, 1998; Faanes, 1987; Brown et al.,

1987 cited in Deng, 1998; McNeil et al., 1985). This risk factor exists within the West Preferred Corridor and adjacent habitats due to the presence of five endangered and threatened species and more than 30 species of concern (Table 1). However, it should be noted that some of these species, such as the crested caracara and the Florida sandhill crane, are rarely observed within freshwater marshes of Everglades National Park.

Avian risk assessment of the proposed West Preferred Corridor

The risk of injury and mortality may be to individual birds, to localized aggregations of birds, e.g., colonies, or to populations. One major caveat to our risk assessment methodology is the lack of scientific data that prevented us from rigorously assessing every species that could be impacted by the power lines. For example, abundance data were not available for all species within taxonomic groupings, such as the raptors. Therefore, we made generalizations regarding estimated risks to broader taxonomic groupings. However, our assessment should be interpreted with caution since there may be some exceptions to these generalized conclusions and they may require revision once additional data on impacts to avian species are obtained from future transmission power line studies.

We evaluated the interrelated and potentially compounding impacts of the risk factors. All avian species occurring within the West Preferred Corridor and adjacent habitats (Table 1) would experience some level of risk of collision with the transmission power lines; however, the magnitude of potential collision risk will differ among species. Although the flight patterns for every species listed in Table 1 are not known, many (if not all) of the species may cross the proposed West Preferred Corridor because similar habitat exists in the Pennsuco Wetlands to the northeast and other potential habitat directly to the east and southeast. Not all species and bird groups are at the same level of risk of collision or electrocution with the transmission power lines. We therefore conducted a qualitative assessment of the risk of injury and mortality from the proposed West Preferred Corridor transmission lines to raptors, wading birds, waterfowl, and passerines using information on specific nesting colonies, species assemblages, and avian populations in the area. We defined the risk levels in the following manner:

- Low risk = Individual bird mortality may occur but the number of birds killed annually is not anticipated to substantially impact the size or productivity of local bird aggregations, such as nesting colonies or flocks of migrants.
- Moderate risk = Individual bird mortality is anticipated; the level of mortality is anticipated to add significantly to the natural mortality rate, which would negatively impact the productivity of local bird aggregations, such as nesting colonies or flocks of migrants, but not cause deleterious effects to the population.

- High risk = Individual bird mortality is anticipated and the level of mortality will add to the natural mortality rate and have the potential to deleteriously impact the population.

Passerines. Many of the migratory passerines that land in, forage in, or seasonally inhabit Everglades National Park have the potential to cross the proposed West Preferred Corridor. Though passerine mortality typically does not constitute the highest rate of transmission power line mortality from collisions, it has been documented (Deng, 1998; Faanes, 1987; Malcolm, 1982). Faanes (1987) reported that passerines comprised 18.1% of all transmission power line mortalities in the spring and 6.6% of all transmission power line mortalities in the fall at seven study sites in the northern Great Plains. Passerines in the vicinity of the West Preferred Corridor are not likely to be susceptible to all of the risk factors known to impact avian injury and mortality rates with transmission power line structures (Table 5). For example, passerines have a small wing-span and generally are not anticipated to produce streamers. Therefore, risk of electrocution is low. In addition, the morphology of passerines does not suggest that they would be at high risk for collisions with transmission power line structures. However, some passerines breed in the West Preferred Corridor and adjacent areas. Juvenile passerines, which are less familiar with the landscape than adults and less maneuverable, may be at increased risk of collision with the proposed power lines as compared to adults. Therefore, we conclude that, while low, a risk is posed to a diverse and abundant assemblage of passerine species that are anticipated to inhabit and migrate through the West Preferred Corridor and adjacent areas.

Raptors. Some raptors, such as vultures, hawks, and ospreys, may be susceptible to many, though not all, of the risk factors known to affect avian injury and mortality rates resulting from exposure to transmission power lines. Vultures and other raptors that perch on the power lines would be at risk of electrocution caused by streamers. Florida Power and Light recently reported suspect streamer-induced kills in Florida (Florida Power and Light unpublished data, 2010). Vulture and raptor species exist in the area and may perch on the proposed power lines, but their abundances are unknown. Streamer-related mortality data collected by Florida Power and Light in Florida indicate a low incidence of (suspect) streamer-induced mortality for vultures (Florida Power and Light unpublished data, 2010). However, streamer-related incidents may not all be detected and reported.

Raptors, including the Everglade snail kite, osprey, red-shouldered hawk (*Buteo lineatus*), turkey vulture (*Cathartes aura*), and black vulture (*Coragyps atratus*), are anticipated to forage and breed within the West Preferred Corridor and adjacent areas (Table 1). Juveniles of these species are anticipated to occur in the West Preferred Corridor and adjacent areas and they may be more susceptible to collisions and electrocutions with the proposed transmission power lines than adults. A juvenile bald eagle (*Haliaeetus leucocephalus*) was killed from a reported transmission power line collision in Florida in 2006, providing some evidence that juvenile

raptors of some species may be at some risk of mortality from collision with transmission power line structures (Florida Power and Light unpublished data, 2010). Other raptors with the potential to occur and forage in the West Preferred Corridor and adjacent areas include the American kestrel, bald eagle, red-tailed hawk (*Buteo jamaicensis*), peregrine falcon (*Falco peregrinus*), and the merlin (*Falco columbarius*). All of these raptors have previously been reported as killed from collisions with power lines in Florida (Florida Power and Light, 2007). Other relatively rare or uncommon raptor species anticipated to occur and forage in the West Preferred Corridor, but that have not been reported as killed from collisions with power lines in Florida, include the Cooper's hawk (*Accipiter cooperii*), sharp-skinned hawk (*Accipiter striatus*), broad-winged hawk (*Buteo platypterus*), and rough-legged hawk (*Buteo lagopus*) (Table 1).

Adult raptors are highly maneuverable and they would likely be at low risk of collisions with the proposed power lines, except perhaps when they are distracted by behaviors that affect their flight characteristics (e.g., aerial breeding displays) (Thompson, 1978). Although some raptor species meet many of the risk factors known to affect avian injury and mortality rates, the existing data provided from Florida Power and Light indicate a low incidence of streamer-induced mortality and the literature review indicates a low risk of collision-induced mortality. However, the literature and data review clearly indicate that some raptor species do experience some level of mortality from power line structures (Florida Power and Light, 2007; Malcolm, 1982). Therefore, the Western Preferred Corridor may pose low overall risk to most raptors.

Of particular importance in this group is the endangered Everglade snail kite. Any increased mortality to the Everglade snail kite may be significant to this population estimated at less than 1,000 birds (Cattau et al., 2009). Deng (1998) hypothesized that Everglade snail kites were at low risk of collision with the power line because of their slow flight patterns, high maneuverability, and diurnal habits. Based on our existing data sources, there are no known Everglade snail kite injuries or mortalities reported from utility structures in Florida (Florida Power and Light unpublished data, 2010; U.S. Fish and Wildlife Service unpublished data, 2010; Florida Power and Light, 2007; Deng, 1998).

Radio transmitter studies on Everglade snail kites have revealed widespread movements between wetland systems in the Everglades and have documented these patterns to include movements across Shark River Slough in a northeasterly direction towards the Pennsuco wetlands, directly across the proposed West Preferred Corridor (Kitchens et al., 2002). Two nesting pairs of Everglade snail kites were recently reported in the footprint of the proposed West Preferred Corridor during the 2010 breeding season (Dial Cordy, 2010). The risk of Everglade snail kite power line collisions may increase during the breeding season when birds may be distracted by aerial displays. Everglade snail kites are known to perform aerial displays at heights as high as 984 ft (Sykes, 1987), within the height dimensions of the proposed West

Preferred Corridor power lines. Juvenile Everglade snail kites that are not as familiar with the landscape, and with less developed flight maneuverability, may be at increased risk of collision as compared to adults. Although Deng's (1998) assessment of collision risks of mature snail kites with power lines may be accurate in general, even adults are at some risk of collision with the West Preferred Corridor due to its placement within known snail kite flight patterns (Kitchens et al., 2002).

Increased mortality rates anticipated to result from exposure to the proposed power lines have the potential to more severely impact special status raptor species, such as the Everglade snail kite and the American kestrel, that are anticipated to occur in the West Preferred Corridor and adjacent areas, than other raptor species. In summary, our assessment indicates that most raptors in the West Preferred Corridor may be at low risk from hazards presented by the proposed West Preferred Corridor power lines. Risk to the Everglade snail kite and the American kestrel, may be elevated, but this is relatively uncertain.

Waterfowl. Waterfowl are not likely to be susceptible to many of the risk factors known to impact avian injury and mortality rates that are associated with transmission power line structures (Table 5). For example, the waterfowl species are not federal- or state-listed, are not likely to produce streamers, and not all species are anticipated to breed in the West Preferred Corridor and adjacent areas. Waterfowl are likely to have a low risk of electrocution because they do not typically perch on transmission power lines and are not known to produce streamers, however, their morphology and flight characteristics makes them vulnerable to transmission power line collisions. Collision rates reported by Malcolm (1982), in a study of more than 4,000 bird collisions in Montana, were not distributed equally amongst all species; blue-winged teals, the American coot (*Fulica americana*), and the green-winged teal (*Anas crecca*) ranked within the top five species accounting for the majority of collision mortalities. These three waterfowl species occur within the West Preferred Corridor, and previous deaths by collisions with power lines in Florida have been documented (Florida Power and Light, 2007). The morphology and migratory patterns of waterfowl species places them at risk of collision with the proposed power line structures. Therefore, based on the literature review, we anticipate that waterfowl would experience a low-to-moderate risk of injury and mortality from the proposed power line structures.

Wading birds. Multiple wading bird species are susceptible to many of the risk factors known to affect injury and mortality rates caused by transmission power lines. We considered the potential risk of electrocution in our risk assessment for wading birds. Because of lack of published data, it is uncertain if some of the wading bird species in the project area, such as wood storks, reddish egrets, and tricolored herons, would perch on the proposed transmission power lines and be at risk of injury and mortality from electrocution. There were no reported

wading bird mortalities suspected from streamers reported in Florida from Florida Power and Light from January 1, 2005, through May 21, 2010 (Florida Power and Light unpublished data, 2010). Streamer-induced mortality was reported at low levels for vultures only (Florida Power and Light unpublished data, 2010). Therefore, risk of injury and mortality to wading birds from electrocution is anticipated to be low, at least for some species.

The wading bird colonies within and adjacent to the proposed West Preferred Corridor transmission lines contribute to the overall size and productivity of regional populations. Nesting wading birds are susceptible to most of the risk factors known to affect avian collision rates with transmission power lines (Table 5). The morphology of wading birds, with their heavy bodies and small wings, makes them less maneuverable than other species, such as raptors or passerines, and places them at increased risk of collision with power lines. Wading bird species that nest in the 3B Mud East, Tamiami, and Grossman Ridge West colonies, including wood storks, great blue herons, snowy egrets, little blue herons, tricolored herons, white ibis, black-crowned night herons, yellow-crowned night herons, great blue herons, and great egrets, would be especially vulnerable to impacts from the proposed transmission power lines. The migratory and daily flight patterns, flight altitudes, and abundance of juveniles place the nesting colonial wading birds adjacent to the West Preferred Corridor at the greatest risk of injury and mortality from the power lines compared to all other bird species and bird groups. These wading bird species have all been previously reported as killed by collisions with Florida Power and Light utility structures (data sources as reported and cited in Florida Power and Light, 2007).

During seasonal migrations, wading birds may cross the West Preferred Corridor to reach foraging and breeding grounds within WCA-3A and Everglades National Park. Nesting wading birds within the 3B Mud East, Tamiami, and Grossman Ridge West colonies are vulnerable because they are likely to frequently cross the West Preferred Corridor to reach foraging grounds in order to meet the energetic demands of developing chicks. For example, wood storks are known to provide an average of approximately four chick feedings per day, up to a maximum of eight chick feedings per day (Clark, 1980). Wood storks in the Everglades forage 6.40 ± 8.32 miles (mean ± 1 standard deviation) from their nesting colony (Herring and Gawlik, 2007). Average wood stork foraging distances for the 3B Mud East, Tamiami, and Grossman Ridge West colonies overlap wetland habitats located on either side of the proposed West Preferred Corridor (Fig. 7D).

A study following bird flight documented the spatially and temporally shifting foraging habitats used by Tamiami West wood storks in relation to foraging water depths (Herring and Gawlik, 2007). It documented the need for foraging habitats in the areas east and northeast of the West Preferred Corridor (Herring and Gawlik, 2007). Wood storks foraged to the northeast

in the Pennsuco wetlands at the beginning of the breeding season when water levels in habitats near the colony were too deep for foraging; as the dry season progressed, wood storks selected foraging habitats within and near the colony (Herring and Gawlik, 2007). With the implementation of various Everglades restoration projects, water depths in the immediate area may increase, thereby increasing the importance of wetlands adjacent to wading bird colonies in the area for supplying a diversity of foraging options throughout the nesting season. Wood storks nesting at the Tamiami colonies, the 3B Mud East colony, and the Grossman Ridge West colonies are likely to cross the West Preferred Corridor to reach other suitable foraging sites within their average foraging radius of 6.40 ± 8.32 miles (mean \pm 1 standard deviation) miles from the colony (Herring and Gawlik, 2007). Mean foraging distances of other wading bird species from a study following bird flight conducted in WCA-3 range from approximately 2 to 19 miles (Table 6).

The largest foraging aggregations of the five wading bird species listed in Table 6 were more than 12.4 miles from the colony by mid-May (Bancroft et al., 1994). Although this study cannot specifically predict foraging flight paths in the proposed project area, it does give a relative estimate of the foraging distances used by these wading bird species that nest within 3B Mud East, Tamiami, and Grossman Ridge West colonies. Because the Pennsuco Wetlands to the east of the West Preferred Corridor are within the reported foraging distances of several species in the area, wading bird foraging flight patterns for multiple species in the area may cross the West Preferred Corridor (Table 6). Further, nesting wading bird species that forage nocturnally, such as wood storks, great blue herons, and black-crowned night herons, may be at greatest risk due to the reduced visibility of power line structures at night (Deng, 1998).

Both wading bird parents actively participate in nest building and nestling care (Clark, 1980). Therefore, the loss of one parent to transmission power line mortality may lead to nest abandonment and increased mortality rates for nestlings. Juvenile wading bird species are at increased risk of injury and mortality with the proposed power lines as compared to adult wading birds due their lack of familiarity with their surroundings and limited flight capabilities.

In particular, the wood stork's endangered status, morphology, breeding locations, abundance of juveniles, and known flight patterns place it at moderate to high risk of injury and mortality from the proposed West Preferred Corridor power lines (Janss, 2000; Bevanger, 1998; Savereno et al., 1996). Though uncertain, this species may also be at risk of electrocution from streamer production on the power lines.

Implementation of the West Preferred Corridor may result in a moderate risk to wading birds because of the potential impacts to nesting productivity, including loss of juveniles from the 3B Mud East, Tamiami, and Grossman Ridge West colonies. It is possible that a moderate to high risk could be posed to federal- and state-listed species nesting within the 3B Mud East,

Tamiami, and Grossman Ridge West colonies, such as the wood stork, because of the relative contribution of these colonies to the overall productivity of the nesting colonies in the Everglades. However, more detailed population viability analyses would be needed to further explore the possible population-level impacts to the wood stork and other state-listed wading birds. Wading bird species that forage, but do not nest, in the West Preferred Corridor and adjacent areas, would likely experience a low to moderate risk of injury and mortality from implementation of the proposed power lines.

Conclusions

The objectives of our study were to identify risk factors that affect rates of avian electrocution and collision with transmission power lines, perform an injury and mortality risk assessment for avian resources within Everglades National Park, and describe avian habitat impacts anticipated to result from construction of transmission power lines within the West Preferred Corridor. In addition to potential changes to the natural hydrology of the area, wetland dredging and filling from construction in the West Preferred Corridor would result in the loss of more than 100 acres of habitat used by more than 200 avian species, including loss of breeding habitat used by more than 50 avian species. This loss of habitat would affect a diverse and abundant assemblage of avian species nesting, foraging, and migrating through habitats located within Everglades National Park.

The risk factors that affect avian injury and mortality rates related to power lines are complex and interrelated. Specifics of utility design and mitigation efforts affect avian collision and electrocution risks. Mitigation measures are likely to reduce, but not eliminate, potential negative impacts to wading birds. Although lack of data and design details preclude our ability to quantify avian injury and mortality rates, studies identified through our literature review were useful in identifying risk factors that affect avian injury and mortality rates associated with transmission power lines. These factors include avian morphology, population size, avian behavior including breeding behavior and flight patterns, location of the power line in relation to avian foraging, roosting, and nesting sites, and proximity of the power line to wetland habitats. Every risk factor we identified in the literature review is present in the proposed West Preferred Corridor.

Based on the risk factors identified and available information on species that occur in Everglades National Park, we conducted a qualitative avian risk assessment for select bird groups and species with the potential to occur in the proposed West Preferred Corridor. Results of the risk assessment suggest that wetland-dependent bird species, such as raptors, wading birds, waterfowl, and passerines, are likely to be negatively impacted by the proposed power lines. However, not all bird groups and species are at the same degree of risk of injury

and mortality. Wading bird species, especially those within the 3B Mud East Colony, the Tamiami colonies, and the Grossman Ridge West Colony are at greatest risk of impacts from the proposed transmission lines. Morphology, migratory and daily flight patterns, flight altitudes, and the abundance of juveniles place the nesting colonial wading birds adjacent to the West Preferred Corridor at the greatest risk of injury and mortality as compared to all other avian species and groups. As such, there is a moderate risk to wading birds nesting within the colonies adjacent to the West Preferred Corridor. Greater risk to the endangered wood stork and other state-listed wading birds nesting in the colonies adjacent to the West Preferred Corridor is possible, but additional studies and analyses are recommended to evaluate that possibility.

Restoration of bird-life, in particular, the abundant wading bird colonies that defined the historic Everglades, was and remains a driving force behind Everglades restoration efforts. Many planned restoration projects focus specifically on restoring water flows, depths, and hydroperiods to Northeast Shark River Slough in support of the ecological requirements of the system and with the expectation of improving wading bird habitat and species productivity. The placement of the proposed transmission power line corridor within this area would likely have adverse impacts on our ability to achieve Everglades restoration goals.

A more comprehensive risk assessment for avifauna in and around Everglades National Park will need to evaluate the entire length of the proposed Florida Power and Light Company transmission corridor in Miami-Dade County. This assessment should fully assess the potential for collisions, electrocutions, and habitat loss resulting from all activities associated with construction and maintenance of the facilities in order to understand the cumulative risks associated with the overall project. A more in-depth assessment should also evaluate the consistency and potential interactions of the proposed corridor with the suite of watershed management and ecosystem restoration projects planned for implementation in the habitats within and around Everglades National Park.

Literature Cited

- Avian Power Line Interaction Committee. 2006. Suggested practices for avian protection on power lines: the state of the art in 2006. Edison Electric Institute, Avian Power Line Interaction Committee, and the California Energy Commission. Washington, D.C. and Sacramento, CA.
- Bahat, O. 2010. Mitigation of transmission lines against bird hazards – the Israeli experience. EDM international conference on overhead lines (March 29 – April 1, 2010). Fort Collins, Colorado. 14pp. University of Haifa and the Technion Institute of Technology, Haifa, Israel; BirdsVision Ltd. http://birdsvision.com/image/users/142826/ftp/my_files/downloads/TransmissionLinesMitigation.pdf?id=3371387
Date obtained online: 20 September 2010.
- Bancroft, G.T., Strong, A.M., Sawicki, R.J., Hoffman, W., and S.D. Jewell. 1994. Relationships among wading bird foraging patterns, colony locations, and hydrology in the Everglades. Everglades: the ecosystem and its restoration. Davis, S.M., and J. C. Ogden, eds. 1994. St. Lucie Press, Delray Beach, Florida. 826 pp.
- Bevanger, K. 1994. Bird interactions with utility structures: collision and electrocution, causes and mitigating measures. *Ibis* (136): 412-425.
- Bevanger, K. 1998. Biological and conservation aspects of bird mortality caused by electricity power lines: a review. *Biological Conservation*. Vol. 86 (1): 67-76.
- Brown, W.M., R.C. Drewien, and E.G. Bizeau. 1987. Mortality of cranes and waterfowl from powerline collisions in the San Luis Valley, Colorado. In: J.C. Lewis (ed.). Proceedings of the 1985 Crane Workshop. Platte River Whooping Crane Maintenance Trust, Grand Island, Nebraska. Pp. 128-136, quoted in Deng (1998).
- Burnham, J.T. 1995. Bird streamer flashovers on Florida Power and Light transmission lines. *IEEE Transactions on Power Delivery* (10):2.
- Cattau, C., Kitchens, W., Reichert, B., Olbert, J., Pias, K., Martin, J., and C. Zweig. 2009. Snail kite demography annual report 2009. Prepared for the U.S. Army Corps of Engineers.
- Clark, E.S. 1980. The attentiveness and time budget of a pair of nesting wood storks. *Proceedings of the Colonial Waterbird Group*. 3: 204-215.
- Cook, M.I., and E.M. Call, eds. 2005. South Florida Wading Bird Report. South Florida Water Management District, West Palm Beach, Florida. Vol. 11:1-38.
http://www.sfwmd.gov/portal/page/portal/xrepository/sfwmd_repository_pdf/wadingbirdreport2005.pdf
Date obtained online: 15 September 2010.
- Cook, M.I., and E.M. Call, eds. 2006. South Florida Wading Bird Report. South Florida Water Management District, West Palm Beach, Florida. Vol. 12:1-51.
http://www.sfwmd.gov/portal/page/portal/xrepository/sfwmd_repository_pdf/wadingbirdreport2006.pdf
Date obtained online: 15 September 2010.
- Cook, M.I., and H.K. Herring, eds. 2007. South Florida Wading Bird Report. South Florida Water Management District, West Palm Beach, Florida. Vol. 13: 1 – 58.

http://www.sfwmd.gov/portal/page/portal/xrepository/sfwmd_repository_pdf/wadingbirdreport2007.pdf
Date obtained online: 15 September 2010.

Cook, M.I., and M. Kobza, eds. 2008. South Florida Wading Bird Report. South Florida Water Management District, West Palm Beach, Florida. Vol. 14: 1-58.

http://www.sfwmd.gov/portal/page/portal/xrepository/sfwmd_repository_pdf/wadingbirdreport2008.pdf
Date obtained online: 15 September 2010.

Cook, M.I., and M. Kobza, eds. 2009. South Florida Wading Bird Report. South Florida Water Management District, West Palm Beach, Florida. Vol. 15: 1- 52.

<http://www.sfwmd.gov/portal/pls/portal/docs/15617526.PDF> Date obtained online: 15 September 2010.

Crivelli, A.J., Jerretrup, H., and T. Mitchev. 1988. Electric power lines: a cause of mortality in *Pelecanus crispus* Bruch, a world endangered bird species, in Porto-Lago, Greece. *Colonial Waterbirds*. Vol. 11 (2): 301-305.

Crozier, G. E., and M.I. Cook, eds. 2004. South Florida Wading Bird Report. South Florida Water Management District, West Palm Beach, Florida. Vol. 10: 1-32.

http://www.sfwmd.gov/portal/page/portal/xrepository/sfwmd_repository_pdf/wadingbirdreport2004.pdf
Date obtained online: 15 September 2010.

Crozier, G.E. and D.E. Gawlik, eds. 2003. South Florida Wading Bird Report. South Florida Water Management District, West Palm Beach, Florida. Vol. 9: 1-28.

http://www.sfwmd.gov/portal/page/portal/xrepository/sfwmd_repository_pdf/wadingbirdreport2003.pdf
Date obtained online: 15 September 2010.

Deng, J. 1998. Bird-strike mortality of wetland birds on a 550 kV high-voltage powerline in the Everglades of Florida. Master of Science Thesis. University of Florida, Gainesville, Florida.

Deng, J. and P. Frederick. 2001. Nocturnal flight behavior of waterbirds in close proximity to a transmission powerline in the Florida Everglades. *Waterbirds* Vol. 24 (3) 419-424.

Dial Cordy. 2010. Everglades snail kite observations and nest locations. L31N (L-30) Seepage Management Pilot Project. PDF map from U.S. Fish and Wildlife Service, Vero Beach, Florida. Date obtained: 16 April 2010.

Dunn, J.L. and J. Alderfer, eds. 2008. Field guide to the birds of North America. 5th ed. National Geographic, China. 503 pp.

Dwyer, J.F. 2004. Investigating and mitigating raptor electrocution in an urban environment. Master of Science Thesis. University of Arizona.

<http://filebox.vt.edu/users/jfdwyer/Webpage/Raptor%20Electrocution%20in%20Tucson.pdf> Date obtained online: 20 September 2010.

Erickson, W.P., Johnson, G.D., and D.P. Young, Jr. 2005. A summary and comparison of bird mortality from anthropogenic causes with an emphasis on collisions. USDA Forest Service Gen. Tech. Rep. PSW-GTR-191.

http://www.fs.fed.us/psw/publications/documents/psw_gtr191/Asilomar/pdfs/1029-1042 Date obtained online: 20 September 2010.

Everglades National Park. 2006. U.S. Florida Bird Checklist. U.S. Department of the Interior, National Park Service. Everglades Association, Homestead, Florida.

<http://www.nps.gov/ever/planyourvisit/upload/Bird%20Checklist%202006.pdf> Date obtained online: 15 September 2010.

Faanes, C.A. 1987. Bird behavior and mortality in relation to power lines in prairie habitats. U.S. Department of the Interior. Technical Report 7, Washington, D.C.

Florida Power and Light. 2007. Avian Protection Plan. Prepared by Pandion Systems, Inc., Gainesville, Florida. to Florida Department of Environmental Protection, Tallahassee, Florida, as part of Florida Power and Light First Response to Incompleteness Determination.

http://publicfiles.dep.state.fl.us/Siting/Outgoing/FPL_Turkey_Point/Units_6_7/Completeness/TransmissionLine/FPL_TL_Completeness_Response/FPL_TP_1st_Completeness_Response_TL.pdf Date obtained online: 14 September 2010.

Florida Power and Light. 2009. Turkey Point Units 6 & 7 Site Certification Application submitted to Florida Department of Environmental Protection.

http://publicfiles.dep.state.fl.us/Siting/Outgoing/FPL_Turkey_Point/Units_6_7/Application/SCA%20Appendix%2010.4_Environmental%20Resources%20Permit/ERP%20Section%203,%20part%201%20-%20Attachments%20A,%20B,%20C%20up%20to%20Figure%2057.pdf Date obtained online: 14 September 2010.

Florida Power and Light personal communication. 2010. Personal communication between David Weda, Florida Power and Light and Alicia LoGalbo, Everglades National Park staff. Date information obtained from Florida Power and Light: 18 May 2010.

Florida Power and Light unpublished data. 2010. Avian injury and mortality data collected from Florida Power and Light transmission power line structures in Florida from January 1, 2005 – May 21, 2010. Email correspondence between Florette Braun, Florida Power and Light and Alicia LoGalbo, Everglades National Park: 21 May 2010.

Gawlik, D.E., ed. 1997. South Florida Wading Bird Report. South Florida Water Management District, West Palm Beach, Florida. Vol. 3, Issue 1: 1-12.

http://www.sfwmd.gov/portal/page/portal/xrepository/sfwmd_repository_pdf/wadingbirdreport1997.pdf Date obtained online: 15 September 2010.

Gawlik, D.E., ed. 1998. South Florida Wading Bird Report. South Florida Water Management District, West Palm Beach, Florida. Vol. 4, Issue 1: 1-14.

http://www.sfwmd.gov/portal/page/portal/xrepository/sfwmd_repository_pdf/wadingbirdreport1998.pdf Date obtained online: 15 September 2010.

Gawlik, D.E., ed., 1999. South Florida Wading Bird Report. South Florida Water Management District, West Palm Beach, Florida. Vol. 5, Issue 1: 1-18.

http://www.sfwmd.gov/portal/page/portal/xrepository/sfwmd_repository_pdf/wadingbirdreport1999.pdf Date obtained online: 15 September 2010.

Gawlik, D.E., ed. 2000. South Florida Wading Bird Report. South Florida Water Management District, West Palm Beach, Florida. Vol. 6, Issue 1: 1-27.

http://www.sfwmd.gov/portal/page/portal/xrepository/sfwmd_repository_pdf/wadingbirdreport2000.pdf Date obtained online: 15 September 2010.

- Gawlik, D.E., ed. 2001. South Florida Wading Bird Report. South Florida Water Management District, West Palm Beach, Florida. Vol. 7: 1 – 29.
http://www.sfwmd.gov/portal/page/portal/xrepository/sfwmd_repository_pdf/wadingbirdreport2001.pdf
Date obtained online: 15 September 2010.
- Gawlik, D.E., ed., 2002. South Florida Wading Bird Report. South Florida Wading Bird Report. South Florida Water Management District, West Palm Beach, Florida. Vol. 8: 1-28.
http://www.sfwmd.gov/portal/page/portal/xrepository/sfwmd_repository_pdf/wadingbirdreport2002.pdf
Date obtained online: 15 September 2010.
- Herring, H.K., and D.E. Gawlik. 2007. Linkage of nesting colonies and foraging areas for wood storks in Everglades National Park. Final report submitted to National Park Service, Everglades National Park. Task Agreement No. J5297 05 0009.
- Janss, G.F. 2000. Avian mortality from power lines: a morphologic approach of species-specific mortality. *Biological Conservation*. Vol. 95 (3): 353-359.
- Janss, G.F, and M. Ferrer. 1998. Rate of bird collision with power lines: effects of conductor marking and static wire mapping. *J. Field Ornith.* Vol. 69(1): 8-17.
- Kitchens , W.M., Bennetts, R.E., and D.L. DeAngelis. 2002. Linkages between the snail kite population and wetland dynamics in a highly fragmented south Florida hydroscape. *The Everglades, Florida Bay, and coral reefs of the Florida Keys: an ecosystem sourcebook*. Porter, J.W., and Porter, K.G., eds. CRC Press. Boca Raton, Florida. pp. 184-201.
- Loughlin, M.H., Ogden, J.C., Robertson, W.B., Jr., Russel, K., and R. Wood. 1990. Everglades National Park Bird Checklist: a habitat guide to birds of Everglades National Park. Florida National Parks & Monuments Association, Inc. Homestead, Florida.
- Malcolm, J.M. 1982. Bird collisions with a power transmission line and their relation to botulism at a Montana wetland. *Wildlife Society Bulletin*. Vol. 10 (4): 297-304.
- Manville, A.M. 2005. Bird strike and electrocutions at power lines, communication towers, and wind turbines: state of the art and state of the science - next steps toward mitigation. In: Ralph, C. John; Rich, Terrell D., editors 2005. *Bird Conservation Implementation and Integration in the Americas: Proceedings of the Third International Partners in Flight Conference*. 2002 March 20-24; Asilomar, California, Volume 2 Gen. Tech. Rep. PSW-GTR-191. Albany, CA: U.S. Dept. of Agriculture, Forest Service, Pacific Southwest Research Station: p. 1051-1064. <http://www.treesearch.fs.fed.us/pubs/32105> Date obtained online: 15 September 2010.
- Manville, A.M. 2009. Towers, turbines, power lines, and buildings – steps being taken by the U.S. Fish and Wildlife Service to avoid or minimize take of migratory birds at these structures. *Proceedings of the Fourth International Partners in Flight Conference: Tundra to Tropic*: 1-11.
- Martin, J.M. 2007. Population ecology and conservation of the snail kite. A doctoral dissertation presented to the graduate school of the University of Florida. University of Florida, Gainesville, Florida.
- McNeil, R., Rodriguez S., J.R., and H. Ouellet. 1985. Bird mortality at a power transmission line in northeastern Venezuela. *Biological Conservation* (31): 153-165.

- Public Service Commission of Wisconsin. 2010. Electric transmission lines electricity: from power plants to consumers. psc.wi.gov/thelibrary/publications/electric/electric09.pdf Date obtained online: 14 April 2010.
- Savereno, A.J., Savereno, L.A., Boettcher, R., and S.M. Haig. 1996. Avian behavior and mortality at power lines in coastal South Carolina. *Wildlife Society Bulletin* (24): 636-648.
- Schaub, M. and R. Pradel. 2004. Assessing the relative importance of different sources of mortality from recoveries of marked animals. *Ecology*. Vol. 85 (4): 930-938.
- South Florida Water Management District. 2010. 3B Mud East Colony ArcMap™ shapefile. E-mail correspondence from James Bereens, South Florida Water Management District to Alicia LoGalbo, Everglades National Park: 20 May 2010.
- Spalding, M.G. and D.J. Forrester. 1991. Effects of parasitism and disease on the nesting success of colonial wading birds (Ciconiiformes) in southern Florida. *Fla. Game and Fresh Water Fish Comm. Final Rep.* Tallahassee, Florida. 130 pp.
- Sykes, P.W., Jr. 1987. Some aspects of the breeding biology of the snail kite in Florida. *Journal of Field Ornithology* 58 (2): 171-189.
- Thompson, L.S. 1978. Transmission line wire strikes: mitigation through engineering design and habitat modification. In: Avery, M.L. (ed.), *Impact of Transmission lines on Birds in Flight*. Proceedings of a workshop at Oak Ridge Associated Universities, Oak Ridge, Tennessee, pp. 51-92.
- U.S. Department of Agriculture. 2007. National Agriculture Imagery Program. Available online: <http://www.fsa.usda.gov/FSA/apfoapp?area=home&subject=prog&topic=nai> Date obtained online: 1 October 2010.
- U.S. Fish and Wildlife Service. 1999. South Florida multi-species recovery plan: a species plan...an ecosystem approach. Published by the U.S. Fish and Wildlife Service Southeast Region. Atlanta, GA. 2179 pp. <http://www.fws.gov/verobeach/images/pdflibrary/sf%20ecosystem.pdf> Date obtained online: 19 September 2010.
- U.S. Fish and Wildlife Service. 2005. Clear the Way for Birds! IMBD explores bird collisions. www.fws.gov/birds/documents/Collisions.pdf Date obtained online: 5 May 2010.
- U.S. Fish and Wildlife Service. 2006. Draft Habitat management guidelines for the wood stork in the southeastern U.S. (1st revision). <http://www.fws.gov/verobeach/images/pdflibrary/20060221%20Snail%20Kite%20Management%20Guidelines2.pdf> Date obtained online: 29 September 2010.
- U.S. Fish and Wildlife Service unpublished data. 2010. Avian injury/mortalities data from Bird Fatality/Injury Reporting Database 1/1/1978 to 05/17/2010. Email correspondence between Marci Lockwood, U.S. Fish and Wildlife Service and Dilip Shinde, Everglades National Park: 19 May 2010.

Figures

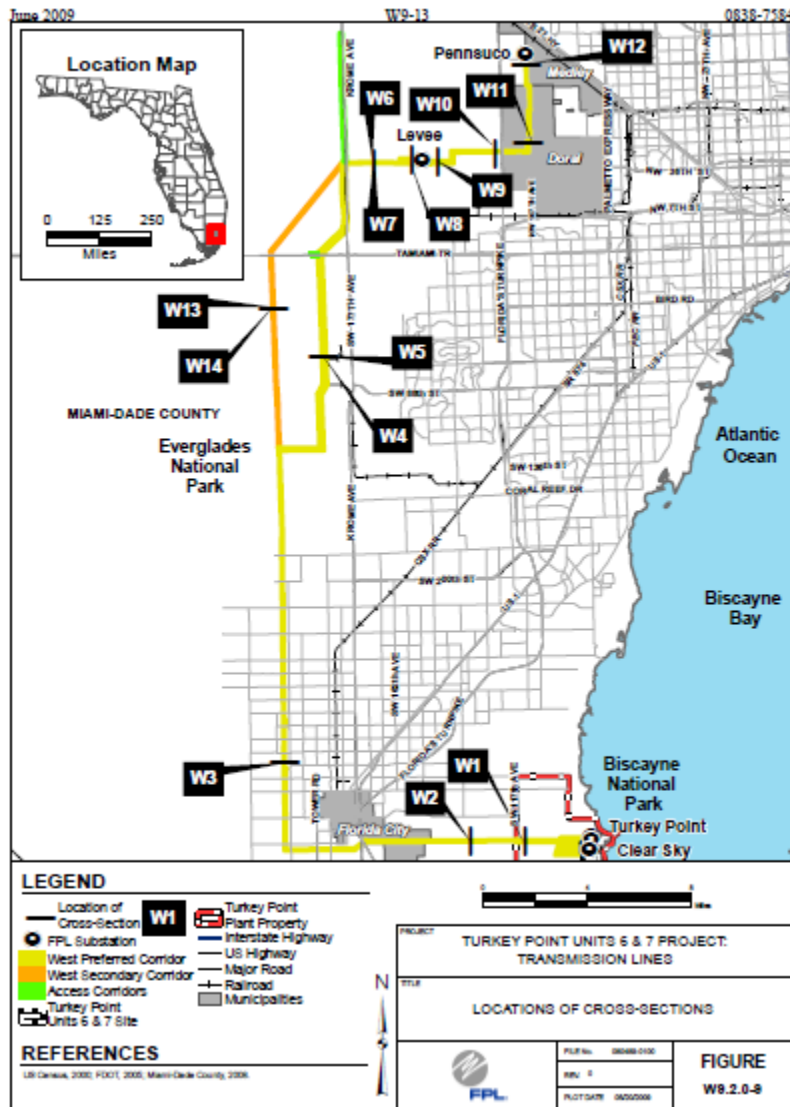
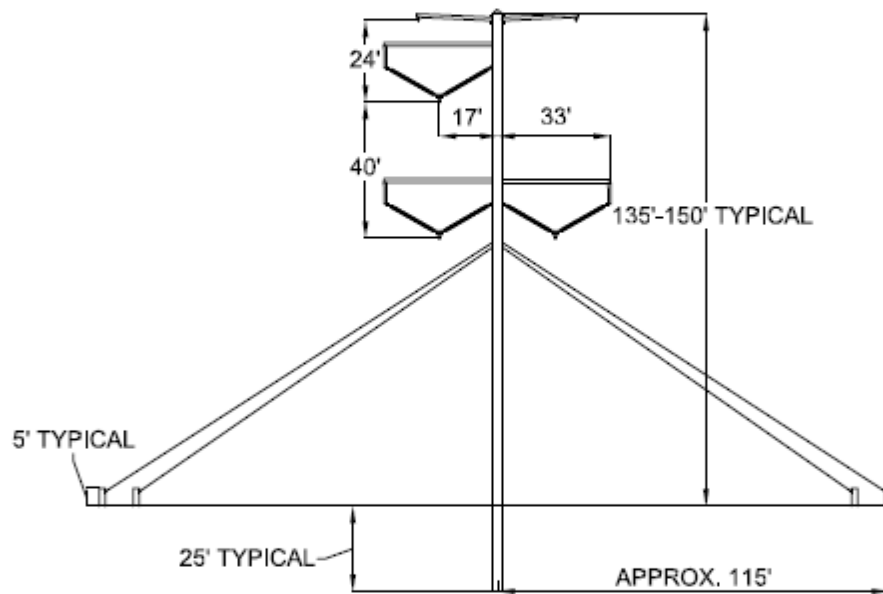

Figure 1. Location of the existing Florida Power and Light West Secondary Corridor (orange) and the proposed Florida Power and Light West Preferred Corridor (yellow).

[Figure courtesy of Florida Power and Light, 2009]

TYPICAL SINGLE-POLE GUYED 500-kV STRUCTURE



NOTE: EACH STRUCTURE WILL HAVE EIGHT GUY WIRES CONNECTED TO CONCRETE PILE ANCHORS.

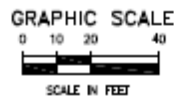

PROJECT		TURKEY POINT UNITS 6 & 7 PROJECT: TRANSMISSION LINES	
FILE		TYPICAL SINGLE-POLE GUYED 500-kV STRUCTURE	
	FILE NO.	080408-0100	FIGURE W9.2.0-2
	REV.	0	
	PLOT DATE	06/18/2009	

ERP FIGURE 5

Figure 2A. Conceptual drawing of the 500-kV transmission power line structure within the West Preferred Corridor.

[Figure courtesy of Florida Power and Light, 2009]

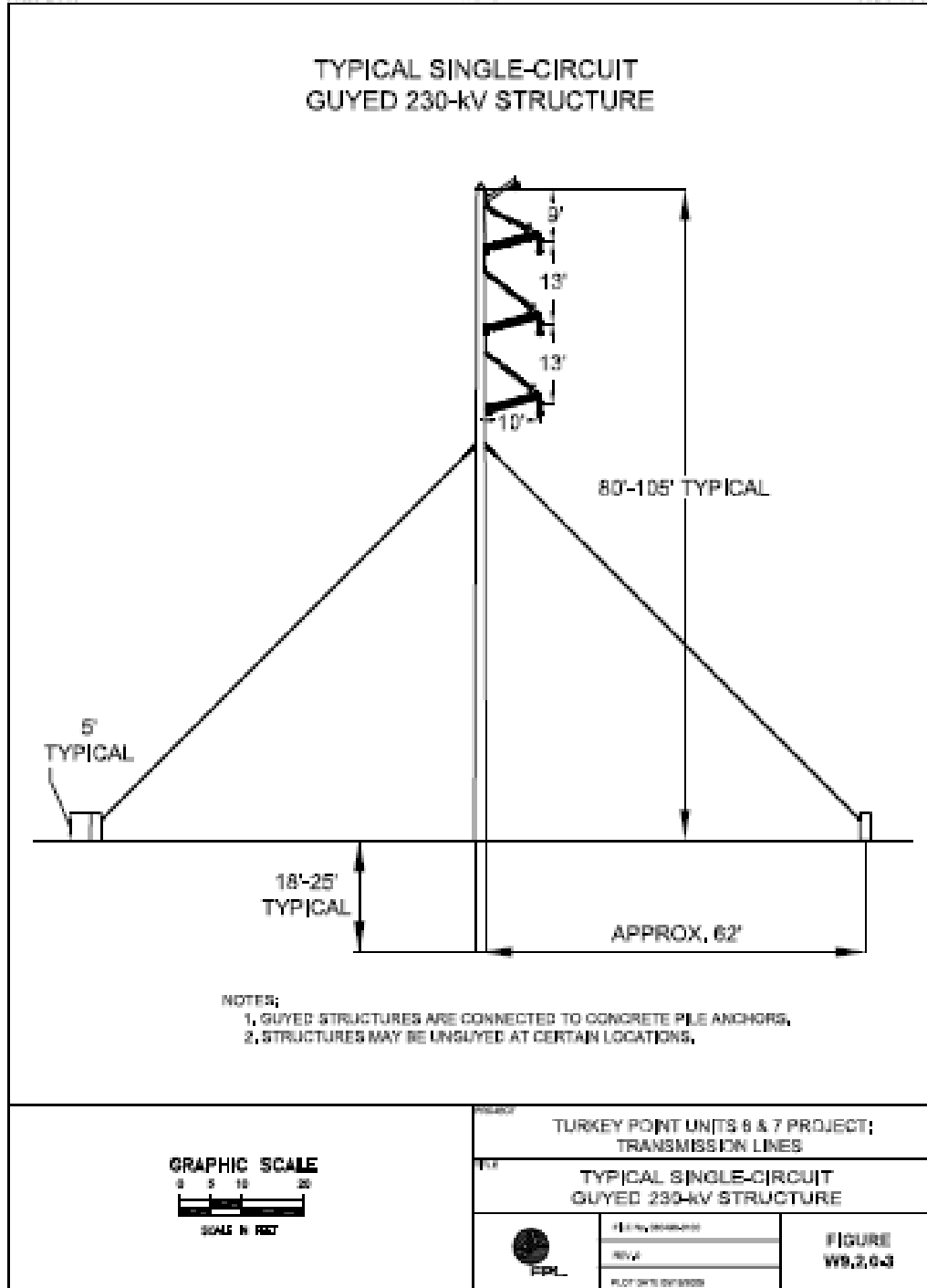

Figure 2B. Conceptual drawing of the 230-kV transmission power line structure within the West Preferred Corridor.

[Figure courtesy of Florida Power and Light, 2009]

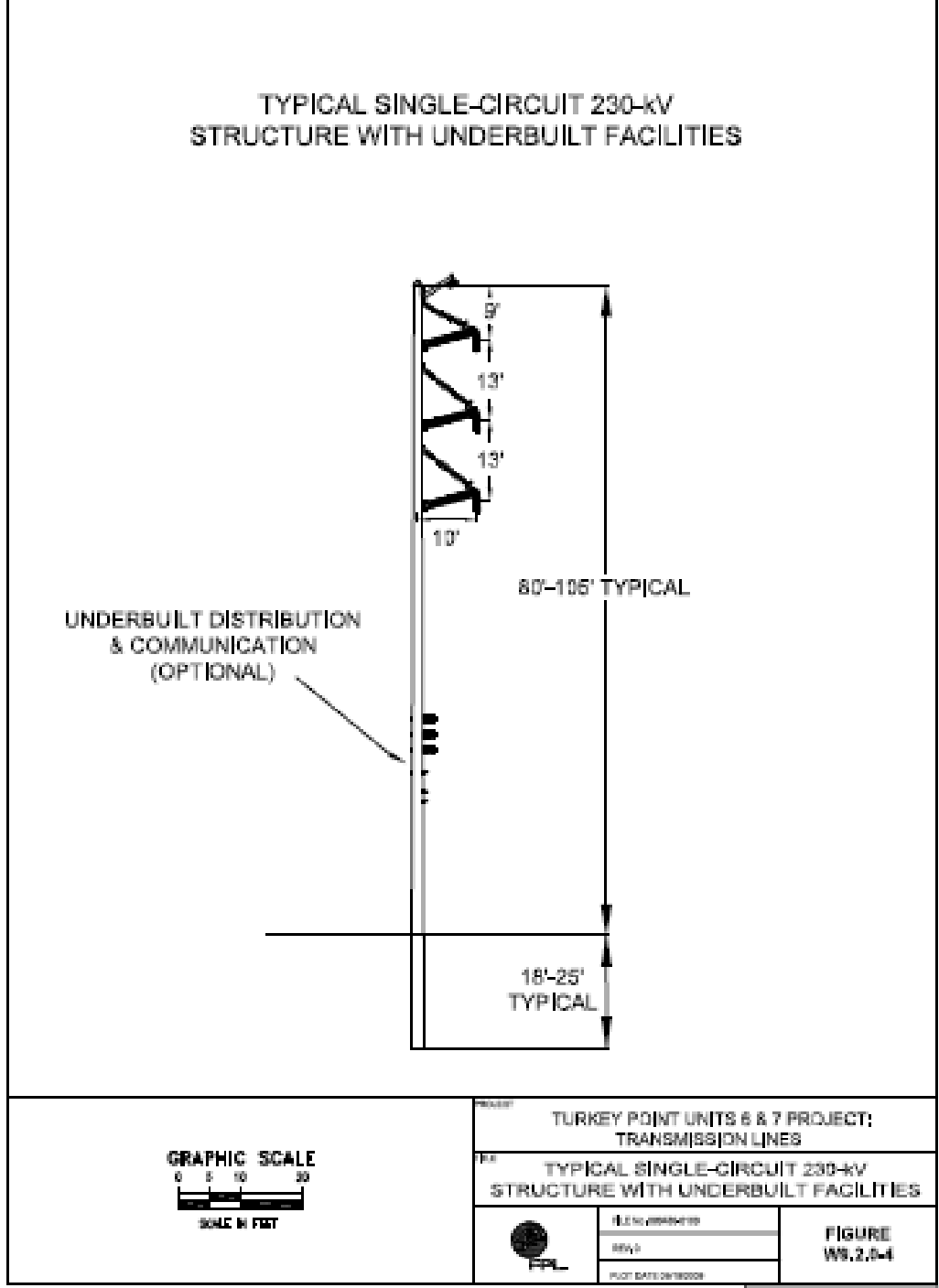
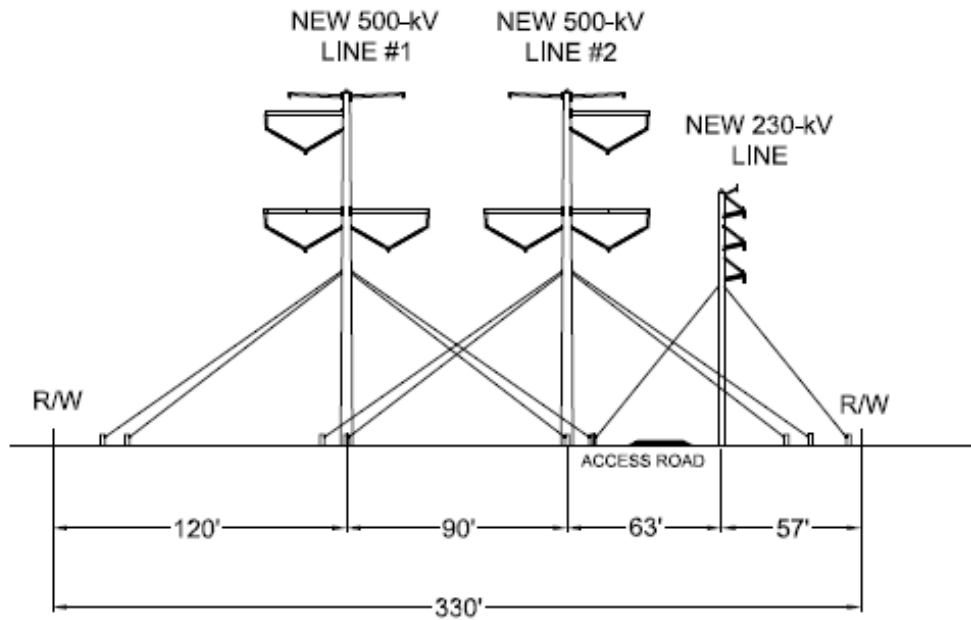

Figure 2C. Conceptual drawing of the 230-kV transmission power line structure within the West Preferred Corridor.

[Figure courtesy of Florida Power and Light, 2009]

(W4) CLEAR SKY-LEVEE #1 & #2 500-kV & CLEAR SKY-PENNSUCO 230-kV DESIGN
ALONG SFWMD LEVEES WITH 230-kV LINE TO WEST
LOOKING SOUTH



- NOTES:
1. STRUCTURES MAY BE SPACED AT DIFFERING INTERVALS LONGITUDINALLY ALONG THE RIGHT-OF-WAY.
 2. CONCEPTUAL CONFIGURATION SHOWN. FINAL CONFIGURATION MAY VARY.

Figure 3A. Conceptual drawing of the two 500-kV transmission power lines and the 230-kV transmission power line structures within the West Preferred Corridor.

[Figure courtesy of Florida Power and Light, 2009]

(W5) CLEAR SKY-LEVEE #1 & #2 500-kV & CLEAR SKY-PENNSUCO 230-kV
DESIGN ALONG SFWMD LEVEES WITH 230-kV LINE TO THE EAST
LOOKING SOUTH
(ALTERNATIVE CONFIGURATION)

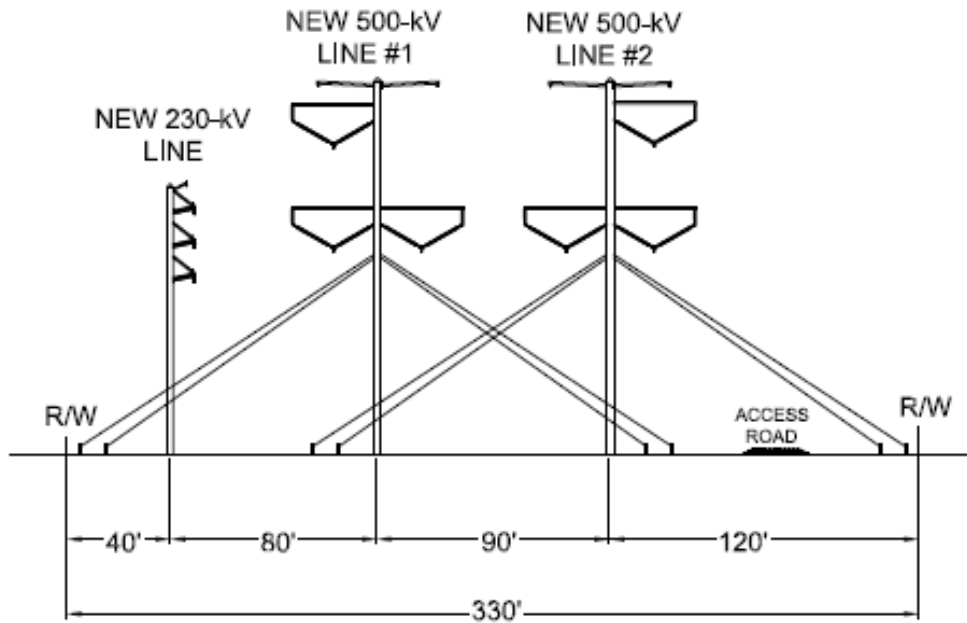

- NOTES:
1. STRUCTURES MAY BE SPACED AT DIFFERING INTERVALS LONGITUDINALLY ALONG THE RIGHT-OF-WAY.
 2. CONCEPTUAL CONFIGURATION SHOWN. FINAL CONFIGURATION MAY VARY.

Figure 3B. Conceptual drawing of the two 500-kV transmission power lines and the 230-kV transmission power line structures within the West Preferred Corridor.

[Figure courtesy of Florida Power and Light, 2009]

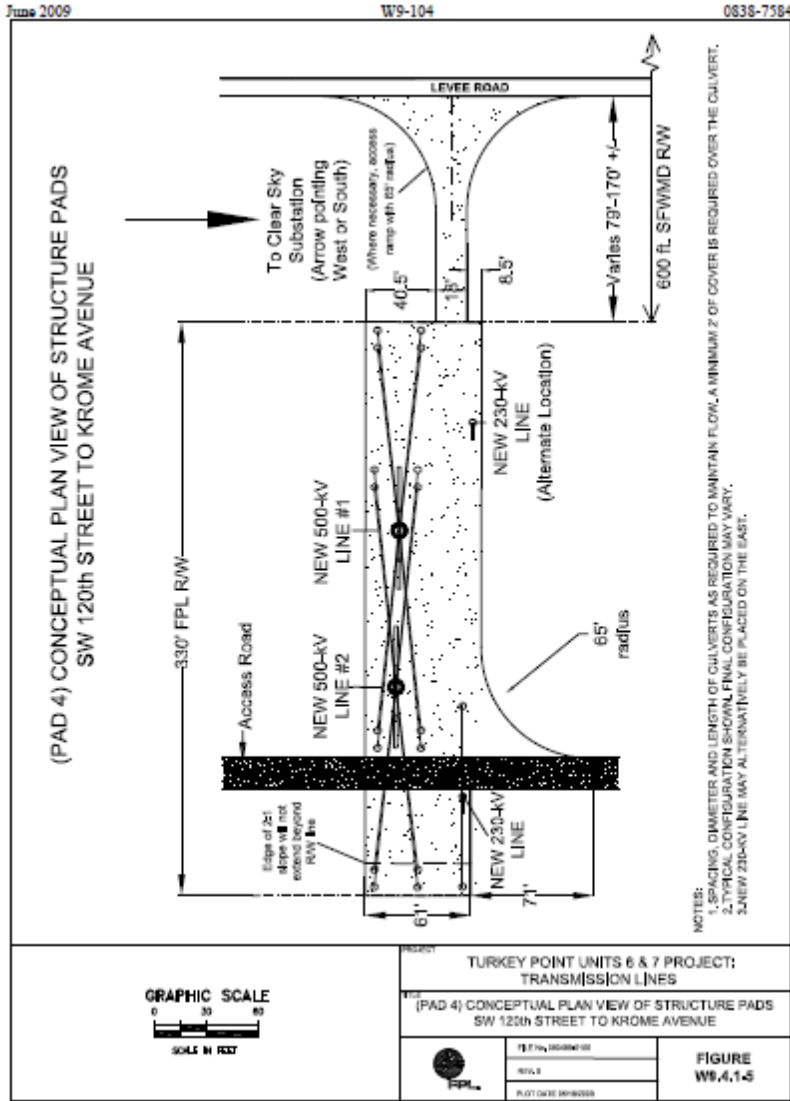

Figure 4A. Overhead conceptual drawing of the two 500-kV transmission power lines and the 230-kV transmission power line features within the West Preferred Corridor.

[Figure courtesy of Florida Power and Light, 2009]

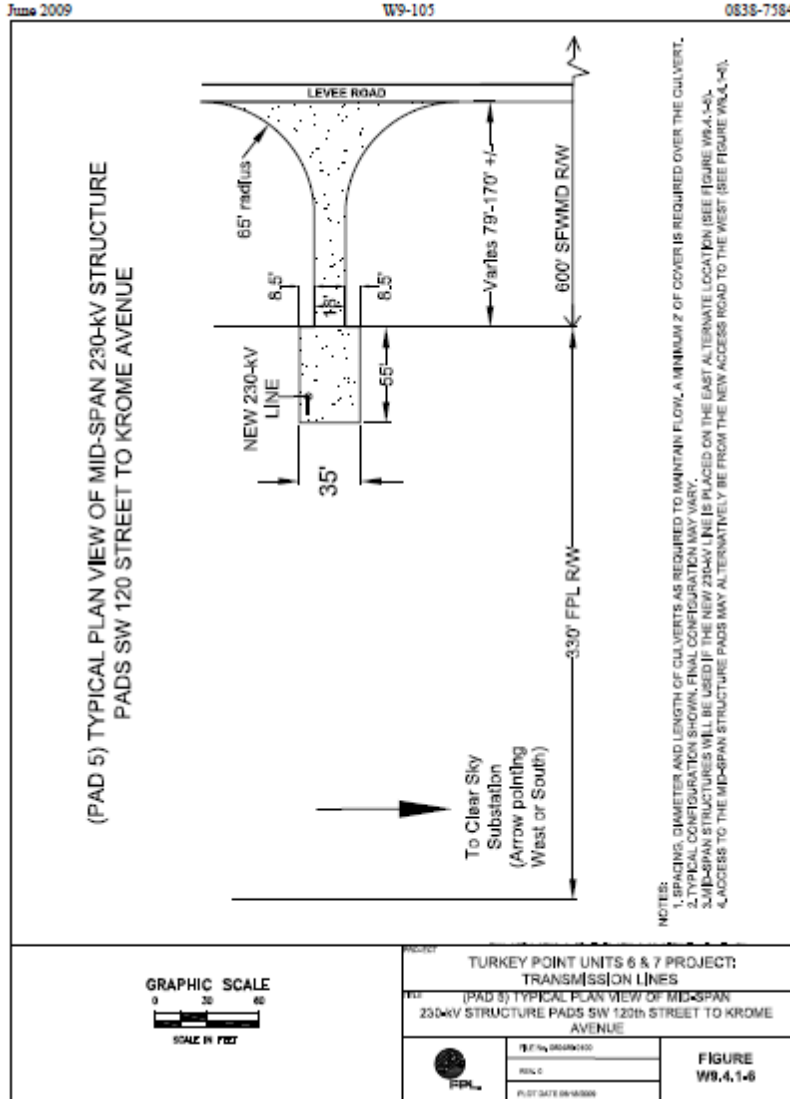

Figure 4B. Overhead conceptual drawing of the solitary 230-kV transmission power line features within the West Preferred Corridor.

[Figure courtesy of Florida Power and Light, 2009]



Figure 5. Estimated bird group electrocution and collision susceptibility with power lines based on principal components analysis of wing size and wing proportions.

[Figure courtesy of Bevanger, 1998]

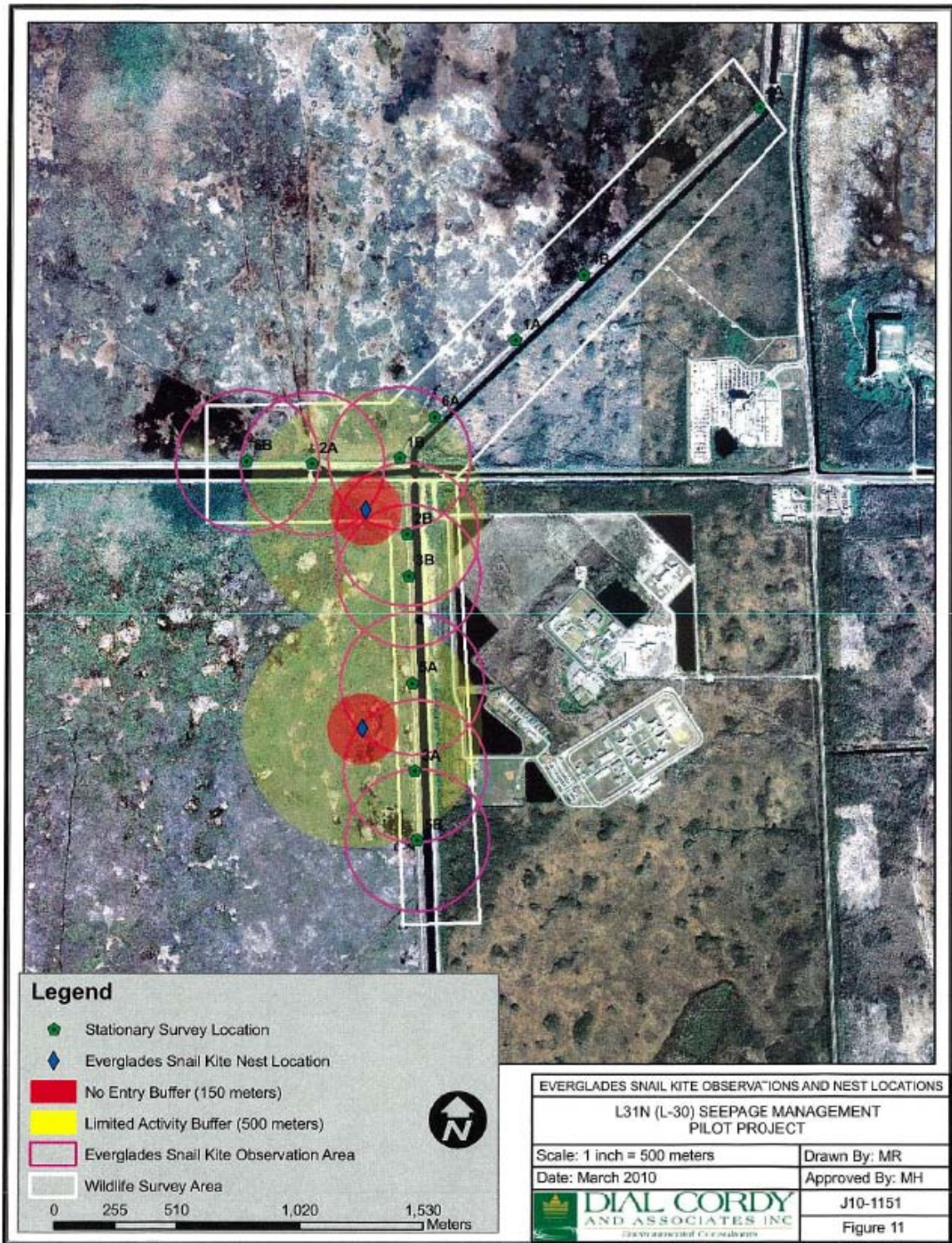

Figure 6. Everglade snail kite nesting locations in the West Preferred Corridor footprint during the 2010 nesting season.

[Figure courtesy of Dial Cordy, 2010]

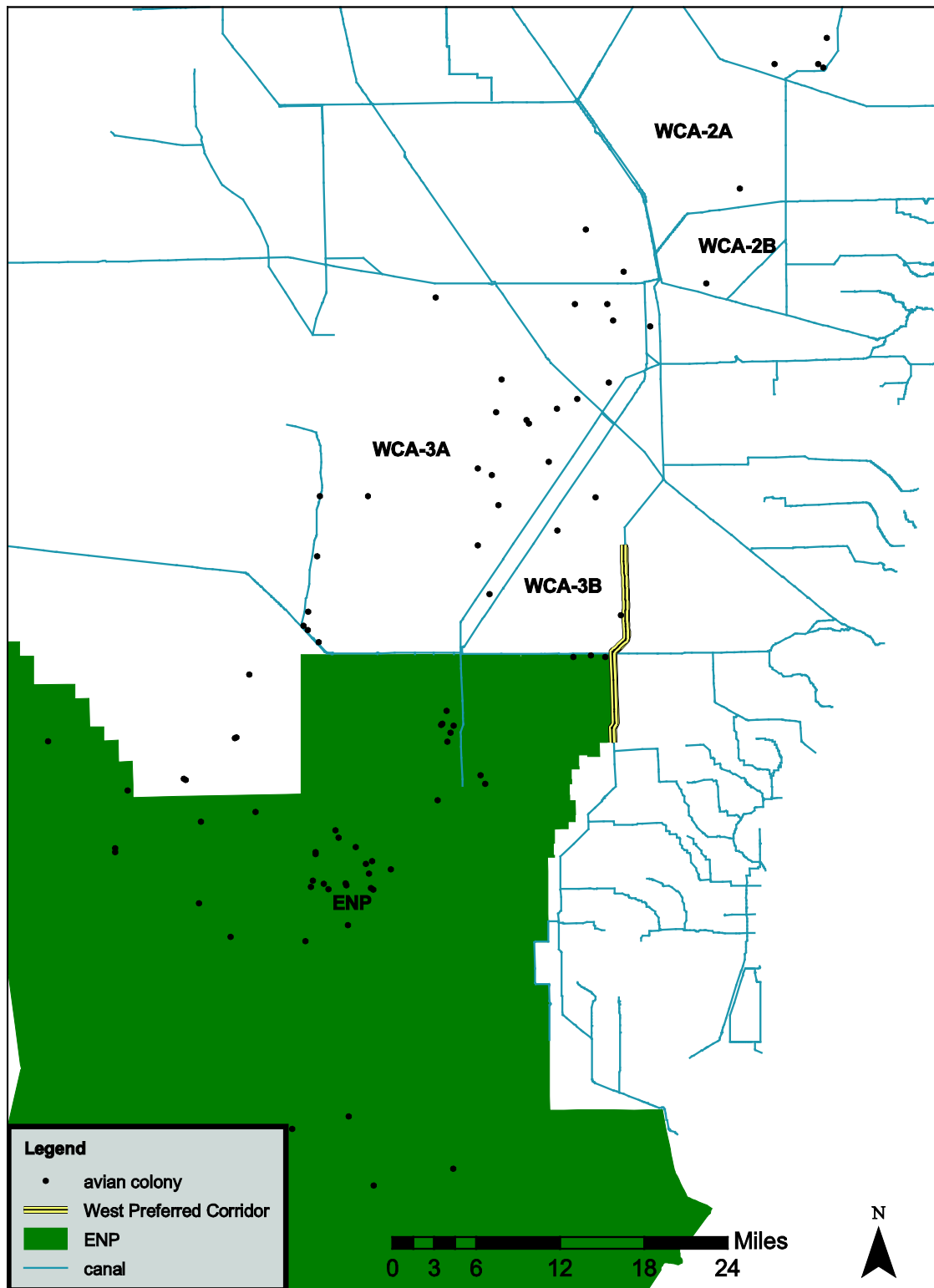

Figure 7A. 2009 Wading bird colonies (multiple species including anhingas) in the Water Conservation Areas (WCA) and Everglades National Park (ENP).

[Data sources: Cook and Kobza, 2009; Florida Power and Light, 2009]

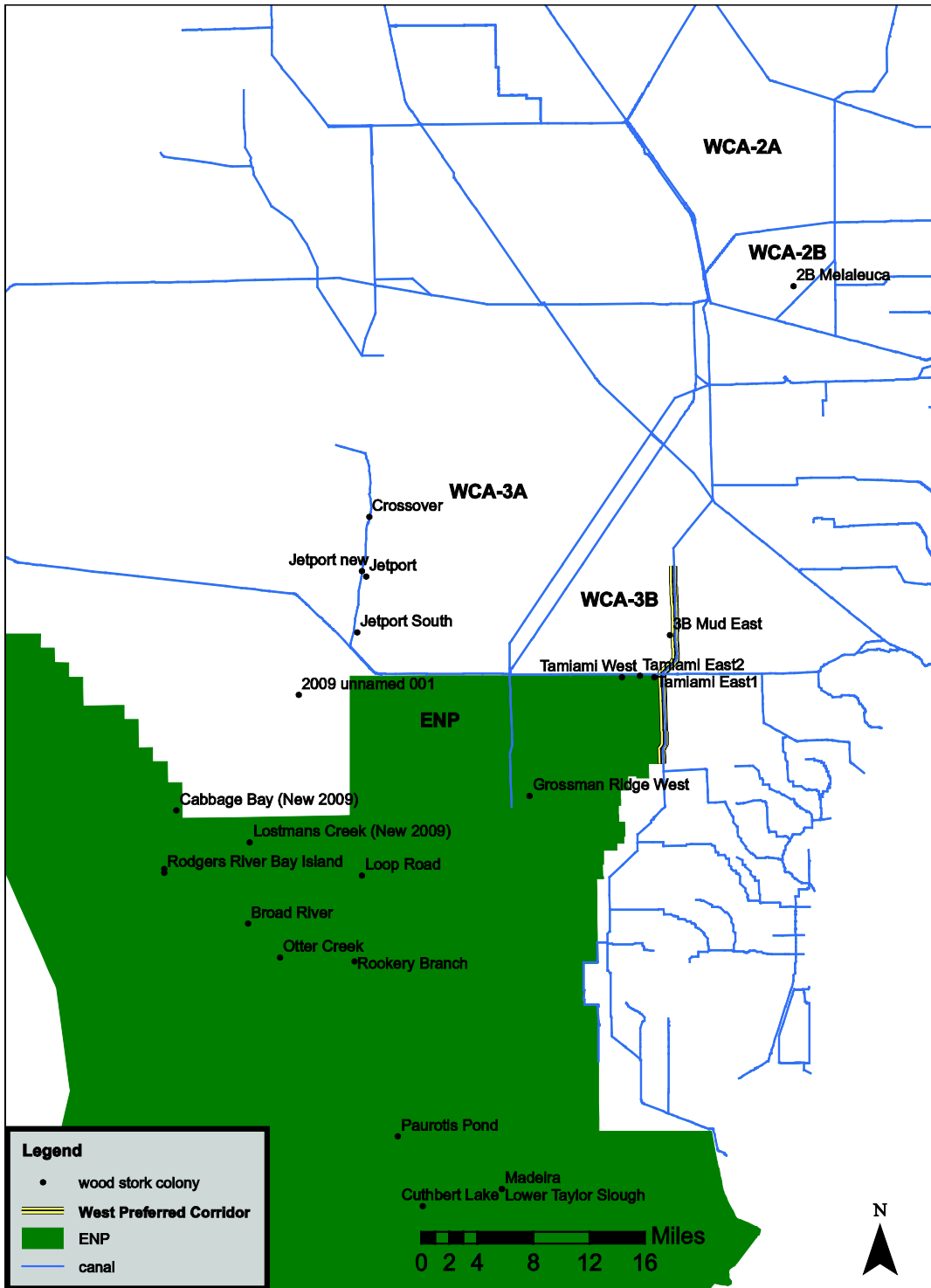

Figure 7B. Wood stork colonies in the WCAs and Everglades National Park.

[Data sources: Cook and Kobza, 2009; Florida Power and Light, 2009; Cook and Kobza, 2008; Cook and Herring, 2007; Cook and Call, 2006; Cook and Call, 2005; Crozier and Cook, 2004; Crozier and Gawlik, 2003; Gawlik, 2002-1997]

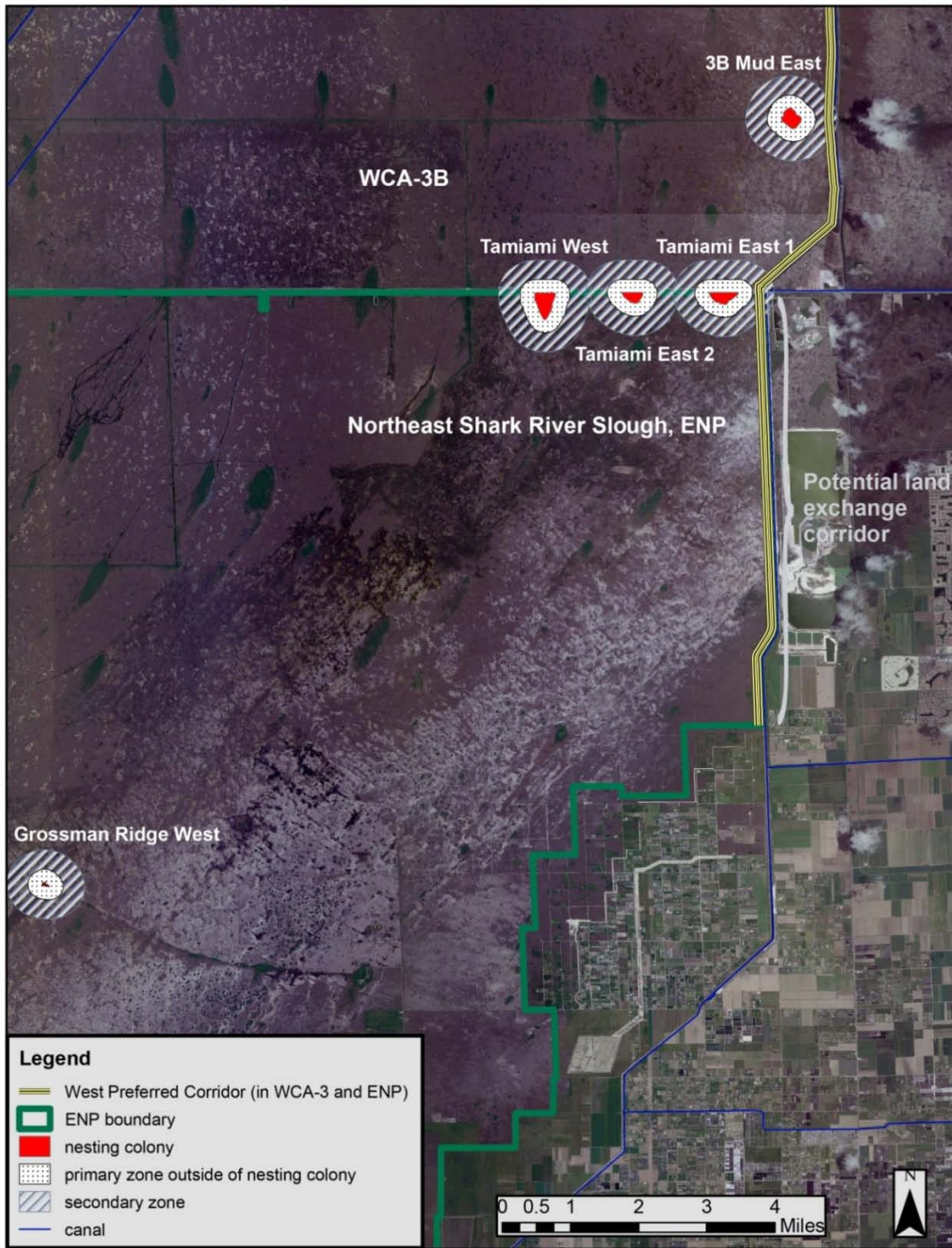

Figure 7C. 3B Mud East, Tamiami, and Grossman Ridge West wood stork colonies and management zones.

[Data sources: South Florida Water Management District, 2010; Cook and Kobza, 2009; Florida Power and Light, 2009; Cook and Kobza, 2008; Cook and Herring, 2007; Cook and Call, 2006; Cook and Call, 2005; Crozier and Cook, 2004; Crozier and Gawlik, 2003; Gawlik, 2002-1997]

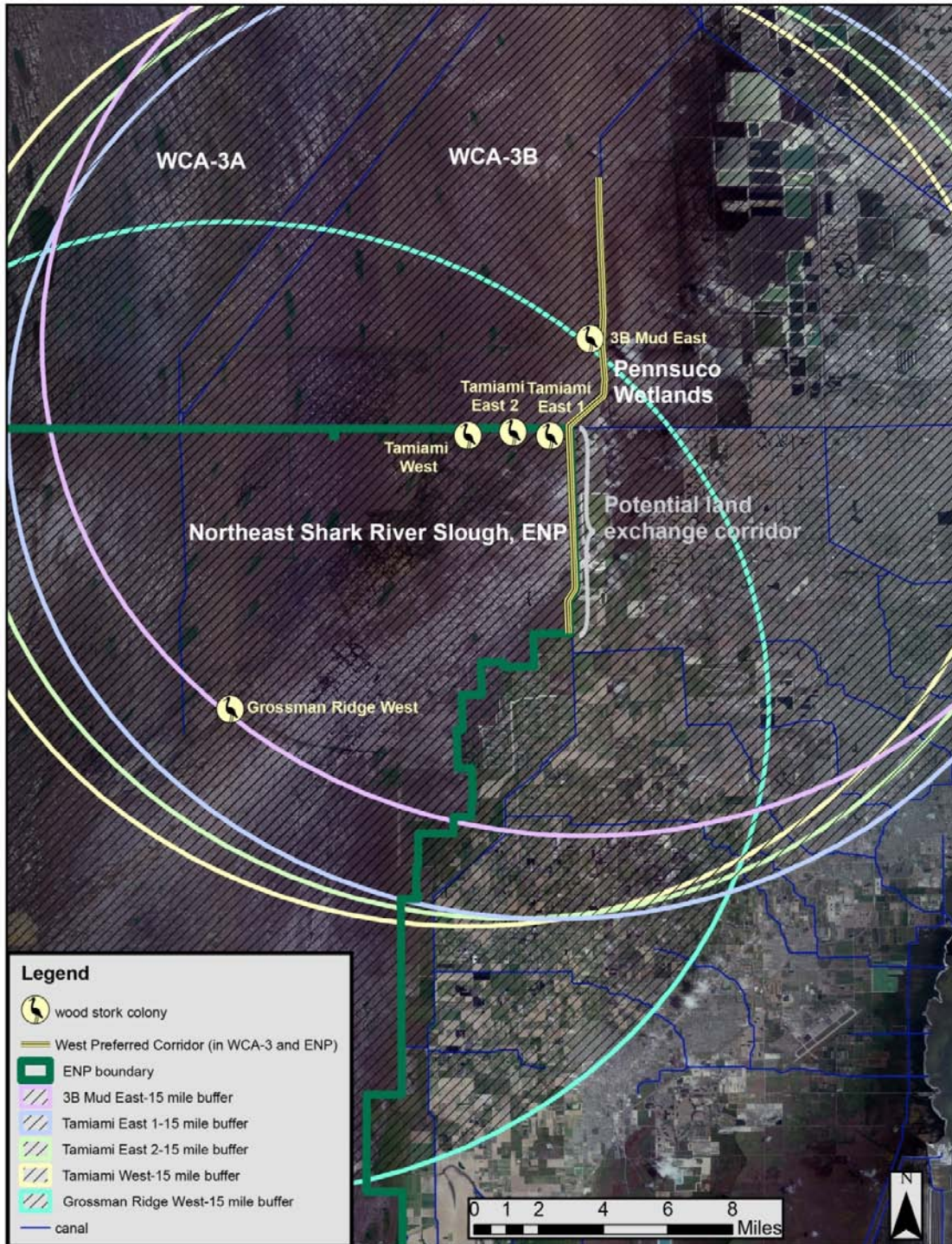

Figure 7D. Average foraging radii (6.40 miles \pm 8.32 miles, mean \pm 1 standard deviation) of the 3B Mud East, Tamiami, and Grossman Ridge West colonies.

[Data sources: Cook and Kobza, 2009; Florida Power and Light, 2009; Cook and Kobza, 2008; Cook and Herring, 2007; Cook and Call, 2006; Cook and Call, 2005; Crozier and Cook, 2004; Crozier and Gawlik, 2003; Gawlik, 2002-1997]

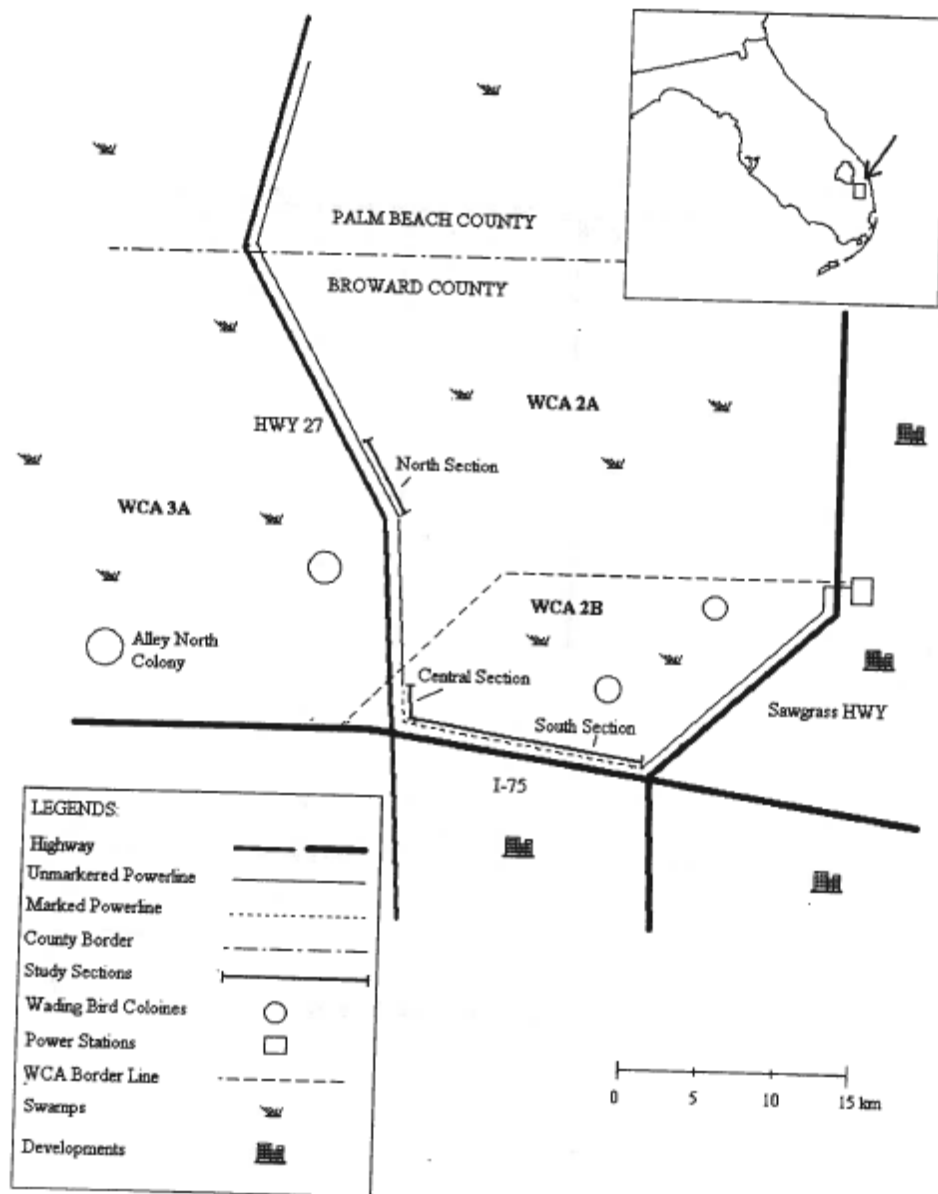

Figure 8. Levee-Midway Power Line study sites in Water Conservation Area-2.

[Figure courtesy of Deng, 1998]

Tables

Table 1. Avian species known or anticipated to occur in the proposed West Preferred Corridor Area and adjacent areas.

[Data sources: Florida Power and Light unpublished data, 2010; data as cited and reported in Florida Power and Light, 2007; Everglades National Park, 2006; Deng, 1998; Loughlin et al., 1990]

Species	Common Name	Federal Status	State of Florida Status	Breeding in Everglades National Park	Breeding in West Preferred Corridor Area ¹	Spring	Summer	Fall	Winter	Reported Florida Utility Injury or Mortality
<i>Accipiter cooperii</i>	Cooper's hawk					r		r	r	
<i>Accipiter striatus</i>	sharp-shinned hawk					u		u	u	
<i>Actitus macularius</i>	spotted sandpiper					c		c	c	
<i>Agelaius phoeniceus</i>	red-winged blackbird			X	X	c	c	c	c	
<i>Aix sponsa</i>	wood duck					r	r	r	r	
<i>Anas acuta</i>	northern pintail					c		r	c	
<i>Anas americana</i>	American wigeon					u	r	u	c	
<i>Anas bahamensis</i>	white-cheeked pintail					r	r	r	r	
<i>Anas clypeata</i>	northern shoveler					c	r	c	c	
<i>Anas crecca</i>	green-winged teal					u		r	u	X
<i>Anas cyanoptera</i>	cinnamon teal						*		*	
<i>Anas discors</i>	blue-winged teal					c	r	c	c	X
<i>Anas fulvigula</i>	mottled duck			X	X	c	c	c	c	X

Species	Common Name	Federal Status	State of Florida Status	Breeding in Everglades National Park	Breeding in West Preferred Corridor Area ¹	Spring	Summer	Fall	Winter	Reported Florida Utility Injury or Mortality
<i>Anas platyrhynchos</i>	mallard					r			r	
<i>Anas rubripes</i>	American black duck								*	
<i>Anas strepera</i>	gadwall							r	r	
<i>Anhinga anhinga</i>	anhinga			X	X	c	c	c	c	
<i>Aquila chrysaetos</i>	golden eagle							*	*	
<i>Aramus guarauna</i>	limpkin	C	SSC	X	X	u	u	u	u	
<i>Archilochus colubris</i>	ruby-throated hummingbird					c	r	c	c	
<i>Ardea alba</i>	great egret			X	X	c	c	c	c	X
<i>Ardea herodias</i>	great blue heron			X	X	c	c	c	c	X
<i>Asio flammeus</i>	short-eared owl					r		r	r	
<i>Aythya affinis</i>	lesser scaup					c		c	c	
<i>Aythya collaris</i>	ring-necked duck					c		c	c	
<i>Aythya marila</i>	greater scaup								*	
<i>Baeolophus bicolor</i>	tufted titmouse					r	r	r	r	
<i>Bartramia longicauda</i>	upland sandpiper					*			*	
<i>Bombycilla cedrorum</i>	cedar waxwing					r-c		r-c	r-c	

Species	Common Name	Federal Status	State of Florida Status	Breeding in Everglades National Park	Breeding in West Preferred Corridor Area ¹	Spring	Summer	Fall	Winter	Reported Florida Utility Injury or Mortality
<i>Botaurus lentiginosus</i>	American bittern	C				u	r	u	c	
<i>Branta canadensis</i>	Canada goose								*	
<i>Bubulcus ibis</i>	cattle egret			X	X	c	c	c	c	X
<i>Bucephala albeola</i>	bufflehead					r			r	
<i>Buteo brachyurus</i>	short-tailed hawk	C		X		u	r	u	u	
<i>Buteo jamaicensis</i>	red-tailed hawk			X		u	u	u	u	X
<i>Buteo lagopus</i>	rough-legged hawk					*		*	*	
<i>Buteo lineatus</i>	red-shouldered hawk			X	X	c	c	c	c	X
<i>Buteo platypterus</i>	broad-winged hawk					u		u	u	
<i>Buteo swainsoni</i>	Swainson's hawk					r		r	u	
<i>Butorides virescens</i>	green heron			X	X	c	c	c	c	X
<i>Calidris bairdii</i>	Baird's sandpiper							*		
<i>Calidris himantopus</i>	stilt sandpiper					u	r	u	r	
<i>Calidris melanotos</i>	pectoral sandpiper					u	r	c		
<i>Caprimulgus carolinensis</i>	Chuck-will's-widow					c	c	c	r	

Species	Common Name	Federal Status	State of Florida Status	Breeding in Everglades National Park	Breeding in West Preferred Corridor Area ¹	Spring	Summer	Fall	Winter	Reported Florida Utility Injury or Mortality
<i>Caprimulgus vociferus</i>	whip-poor-will					u		u	c	
<i>Caracara cheriway</i>	caracara, Audubon's crested	T	T			*	*			X
<i>Cardinalis cardinalis</i>	northern cardinal			X	X	c	c	c	c	
<i>Carduelis pinus</i>	pine siskin						r		r	
<i>Carduelis tristis</i>	American goldfinch					u-c		u-c	u-c	
<i>Cathartes aura</i>	turkey vulture			X	X	c	c	c	c	X
<i>Catharus fuscescens</i>	veery	C				u		u		
<i>Catharus guttatus</i>	hermit thrush					r		u	u	
<i>Catharus minimus</i>	gray-cheeked thrush					*		u		
<i>Catharus ustulatus</i>	Swainson's thrush					u		u	*	
<i>Chaetura pelagica</i>	chimney swift					u		r		
<i>Charadrius vociferus</i>	killdeer			X	X	c	u	c	c	
<i>Chlidonias niger</i>	black tern					u	u	u	r	
<i>Chordeiles minor</i>	common nighthawk			X	X	c	c	c	r	
<i>Circus cyaneus</i>	northern harrier	C				u	r	u	c	

Species	Common Name	Federal Status	State of Florida Status	Breeding in Everglades National Park	Breeding in West Preferred Corridor Area ¹	Spring	Summer	Fall	Winter	Reported Florida Utility Injury or Mortality
<i>Cistothorus palustris</i>	marsh wren		SSC			u		u	u	
<i>Cistothorus platensis</i>	sedge wren	C				u		u	u	
<i>Coccyzus americanus</i>	yellow-billed cuckoo	C		X	X	c	c	c	r	
<i>Coereba flaveola</i>	bananaquit					*			*	
<i>Colaptes auratus</i>	northern flicker	C		X	X	c	c	c	c	
<i>Columba livia</i>	rock pigeon (dove)					*	*	*	*	
<i>Contopus virens</i>	eastern wood-pewee					u		u	r	
<i>Coragyps atratus</i>	black vulture			X	X	c	c	c	c	X
<i>Corvus brachyrhynchos</i>	American crow			X	X	c	c	c	c	X
<i>Coturnicops noveboracensis</i>	yellow rail	C				*		*	*	
<i>Crotophaga ani</i>	smooth-billed ani			X	X	u	u	u	u	
<i>Crotophaga sulcirostris</i>	grove-billed ani					r		r	r	
<i>Cyanocitta cristata</i>	blue jay			X	X	c	c	c	c	
<i>Dendrocygna bicolor</i>	Fulvous whistling-duck					u	r	u	u	
<i>Dendroica caerulescens</i>	black-throated blue warbler	C				c		c	r	

Species	Common Name	Federal Status	State of Florida Status	Breeding in Everglades National Park	Breeding in West Preferred Corridor Area ¹	Spring	Summer	Fall	Winter	Reported Florida Utility Injury or Mortality
<i>Dendroica castanea</i>	bay-breasted warbler					*		*		
<i>Dendroica cerulea</i>	Cerulean warbler							*		
<i>Dendroica coronata</i>	yellow-rumped warbler					u		u	c	
<i>Dendroica discolor</i>	prairie warbler	C		X	X	c	c	c	c	
<i>Dendroica dominica</i>	yellow-throated warbler					c	u	c	c	
<i>Dendroica fusca</i>	blackburnian warbler					u		u	*	
<i>Dendroica magnolia</i>	magnolia warbler					u		u	r	
<i>Dendroica nigrescens</i>	black-throated gray warbler					r		r	r	
<i>Dendroica palmarum</i>	palm warbler					c		c	c	
<i>Dendroica pensylvanica</i>	chestnut-sided warbler					r		r	*	
<i>Dendroica petechia</i>	yellow warbler			X	X	c	c	c	u	
<i>Dendroica striata</i>	blackpoll warbler					c		r		
<i>Dendroica tigrina</i>	Cape May warbler					u-c		u-c	r	
<i>Dendroica virens</i>	black-throated green warbler					u		u	u	

Species	Common Name	Federal Status	State of Florida Status	Breeding in Everglades National Park	Breeding in West Preferred Corridor Area ¹	Spring	Summer	Fall	Winter	Reported Florida Utility Injury or Mortality
<i>Dolichonyx oryzivorus</i>	bobolink	C				c		c	*	
<i>Dryocopus pileatus</i>	pileated woodpecker			X	X	c	c	c	c	
<i>Dumetella carolinensis</i>	grey catbird					c		c	c	
<i>Egretta caerulea</i>	little blue heron		SSC	X	X	c	c	c	c	X
<i>Egretta rufescens</i>	reddish egret	C	SSC	X		u	u	u	u	
<i>Egretta thula</i>	snowy egret		SSC	X	X	c	c	c	c	X
<i>Egretta tricolor</i>	tricolored heron		SSC	X	X	c	c	c	c	X
<i>Elanoides forficatus</i>	swallow-tailed kite	C		X	X	c	c	r		
<i>Elanus leucurus</i>	white-tailed kite			X	X	r	r	r	r	
<i>Empidonax minimus</i>	least flycatcher					u		u	r	
<i>Empidonax traillii</i>	willow flycatcher							*	*	
<i>Empidonax virescens</i>	Acadian flycatcher							*		
<i>Eudocimus albus</i>	white ibis		SSC	X	X	c	c	c	c	X
<i>Euphagus cyanocephalus</i>	Brewer's blackbird					*			r	
<i>Falco columbarius</i>	merlin					u		u	u	X

Species	Common Name	Federal Status	State of Florida Status	Breeding in Everglades National Park	Breeding in West Preferred Corridor Area ¹	Spring	Summer	Fall	Winter	Reported Florida Utility Injury or Mortality
<i>Falco peregrinus</i>	peregrine falcon					u		u	u	X
<i>Falco sparverius paulus</i>	American kestrel		T			c		c	c	X
<i>Fulica americana</i>	American coot			X	X	c	r	c	c	X
<i>Gallinago delicata</i>	Wilson's snipe					u		u	u	
<i>Gallinula chloropus</i>	common moorhen			X	X	c	c	c	c	X
<i>Geothlypis trichas</i>	common yellowthroat			X	X	c	c	c	c	
<i>Grus canadensis pratensis</i>	Florida sandhill crane		T	X	X	u	u	u	u	X
<i>Haliaeetus leucocephalus</i>	bald eagle			X		c	c	c	c	X
<i>Helmitheros vermivorum</i>	worm-eating warbler	C				u		u	r	
<i>Himantopus mexicanus</i>	black-necked stilt			X	X	u	r	u	r	X
<i>Hirundo pyrrhonota</i>	cliff swallow					r	r	u		
<i>Hirundo rustica</i>	barn swallow			X	X	c	c	c	r	
<i>Hylocichla mustelina</i>	wood thrush	C				*		r	*	
<i>Icteria virens</i>	yellow-breasted chat					u		u	u	
<i>Icterus bullockii</i>	Bullock's oriole						r	r	r	

Species	Common Name	Federal Status	State of Florida Status	Breeding in Everglades National Park	Breeding in West Preferred Corridor Area ¹	Spring	Summer	Fall	Winter	Reported Florida Utility Injury or Mortality
<i>Icterus galbula</i>	Baltimore oriole						c	c	r	
<i>Ictinia mississippiensis</i>	Mississippi kite					r		r		
<i>Ixobrychus exilis</i>	least bittern	C		X	X	u	u	u	u	
<i>Junco hyemalis</i>	dark-eyed junco					*		*	*	
<i>Lanius ludovicianus</i>	loggerhead shrike	C		X	X	u	u	u	u	X
<i>Larus argentatus</i>	herring gull					c	u	c	c	
<i>Larus atricilla</i>	laughing gull			X		c	c	c	c	
<i>Larus delawarensis</i>	ring-billed gull					c	u	c	c	
<i>Larus philadelphia</i>	Bonaparte's gull					u			u	
<i>Laterallus jamaicensis</i>	black rail	C				r	r	r	r	
<i>Limnodromus scolopaceus</i>	long-billed dowitcher					u	u	u	r	
<i>Limnothlypis swainsonii</i>	Swainson's warbler	C				r		r	*	
<i>Lophodytes cucullatus</i>	hooded merganser					r		r	u	
<i>Megaceryle alcyon</i>	belted kingfisher					c	r	c	c	
<i>Megascops asio</i>	eastern screech-owl			X	X	c	c	c	c	X

Species	Common Name	Federal Status	State of Florida Status	Breeding in Everglades National Park	Breeding in West Preferred Corridor Area ¹	Spring	Summer	Fall	Winter	Reported Florida Utility Injury or Mortality
<i>Melanerpes carolinus</i>	red-bellied woodpecker			X	X	c	c	c	c	
<i>Melospiza georgiana</i>	swamp sparrow					c		c	c	
<i>Melospiza melodia</i>	song sparrow					*			r	
<i>Mimus polyglottos</i>	northern mockingbird			X	X	c	c	c	c	
<i>Mniotilta varia</i>	black-and-white warbler					c	u	c	c	
<i>Mycteria americana</i>	wood stork	E	E	X	X	u	r	u	u	X
<i>Myiarchus crinitus</i>	great crested flycatcher			X	X	c	c	c	c	
<i>Myiarchus tyrannulus</i>	brown-crested flycatcher					u		u	u	
<i>Nomonyx dominicus</i>	masked duck							*	*	
<i>Nyctanassa violacea</i>	yellow-crowned night heron			X	X	u	u	u	u	X
<i>Nycticorax nycticorax</i>	black-crowned night heron			X	X	c	c	c	c	X
<i>Oporornis agilis</i>	Connecticut warbler					*			*	
<i>Oporornis formosus</i>	Kentucky warbler					r		r	*	
<i>Oporornis philadelphia</i>	mourning warbler							*		

Species	Common Name	Federal Status	State of Florida Status	Breeding in Everglades National Park	Breeding in West Preferred Corridor Area ¹	Spring	Summer	Fall	Winter	Reported Florida Utility Injury or Mortality
<i>Pandion haliaetus</i>	osprey		SSC - Monroe County	X		c	c	c	c	X
<i>Parula americana</i>	northern parula					c	r	c	c	
<i>Passerculus sandwichensis</i>	savannah sparrow					c		c	c	
<i>Passerina caerulea</i>	blue grosbeak					u		u	*	
<i>Passerina ciris</i>	painted bunting	C				c	*	c	u	
<i>Passerina cyanea</i>	indigo bunting					c		c	r	
<i>Patagioenas leucocephala</i>	white-crowned pigeon	C	T	X		c	c	c	u	
<i>Pelecanus erythrorhynchos</i>	American white pelican					c	r	c	c	X
<i>Petrochelidon fulva</i>	cave swallow							r	r	
<i>Phalacrocorax auritus</i>	double-crested cormorant			X		c	c	c	c	X
<i>Phalaropus tricolor</i>	Wilson's phalarope							*		
<i>Pheucticus ludovicianus</i>	rose-breasted grosbeak					u		u	r	
<i>Picoides pubescens</i>	downy woodpecker			X	X	u	u	u	u	
<i>Pipilo erythrophthalmus</i>	eastern towhee			X	X	c	c	c	c	

Species	Common Name	Federal Status	State of Florida Status	Breeding in Everglades National Park	Breeding in West Preferred Corridor Area ¹	Spring	Summer	Fall	Winter	Reported Florida Utility Injury or Mortality
<i>Piranga ludoviciana</i>	western tanager							*		
<i>Piranga olivacea</i>	scarlet tanager					r		r	*	
<i>Piranga rubra</i>	summer tanager					r		r	*	
<i>Platalea ajaja</i>	roseate spoonbill		SSC	X		c	u	c	c	X
<i>Plegadis chihi</i>	white-faced ibis						*			
<i>Plegadis falcinellus</i>	glossy ibis			X		u	u	u	u	X
<i>Podilymbus podiceps</i>	pied-billed grebe			X	X	c	u	c	c	
<i>Polioptila caerulea</i>	blue-grey gnatcatcher					c		c	c	
<i>Porphyrio martinica</i>	purple gallinule			X	X	c	u	c	c	
<i>Porzana carolina</i>	sora					c		c	c	
<i>Protonotaria citrea</i>	prothonotary warbler					u	*	u	*	
<i>Quiscalus major</i>	boat-tailed grackle			X	X	c	c	c	c	X - spp.
<i>Quiscalus quiscula</i>	common grackle			X	X	c	c	c	c	X - spp.
<i>Rallus elegans</i>	king rail			X	X	c	c	c	c	X
<i>Rallus limicola</i>	Virginia rail					r		r	r	
<i>Regulus calendula</i>	ruby-crowned kinglet					u		u	u	

Species	Common Name	Federal Status	State of Florida Status	Breeding in Everglades National Park	Breeding in West Preferred Corridor Area ¹	Spring	Summer	Fall	Winter	Reported Florida Utility Injury or Mortality
<i>Riparia riparia</i>	bank swallow						u	u	*	
<i>Rostrhamus sociabilis plumbeus</i>	Everglade snail kite	E	E	X	X	r	r	r	r	
<i>Sayornis phoebe</i>	eastern phoebe					c		c	c	
<i>Sayornis saya</i>	Sah's phoebe									
<i>Scolopax minor</i>	American woodcock					r			r	
<i>Seiurus aurocapilla</i>	ovenbird					c		c	c	
<i>Seiurus motacilla</i>	Louisiana waterthrush	C				c	u	c	r	
<i>Seiurus noveboracensis</i>	northern waterthrush					c		c	c	
<i>Selasphorus rufus</i>	rufous hummingbird							*	*	
<i>Setophaga ruticilla</i>	American redstart					c	u	c	c	
<i>Sphyrapicus varius</i>	yellow-bellied sapsucker					u		u	c	
<i>Spindalis zena</i>	western spindalis					*			*	
<i>Spiza americana</i>	dickcissel							*	*	
<i>Spizella pallida</i>	clay-colored sparrow					r		r	r	
<i>Spizella passerina</i>	chipping sparrow					u		u	u	

Species	Common Name	Federal Status	State of Florida Status	Breeding in Everglades National Park	Breeding in West Preferred Corridor Area ¹	Spring	Summer	Fall	Winter	Reported Florida Utility Injury or Mortality
<i>Spizella pusilla</i>	field sparrow	C				u		u	u	
<i>Stelgidopteryx serripennis</i>	northern rough-winged swallow					u		u	r	
<i>Sterna caspia</i>	Caspian tern					c	r	c	c	
<i>Sterna forsteri</i>	Forster's tern					c	u	c	c	
<i>Strix varia</i>	barred owl			X	X	c	c	c	c	X
<i>Sturnella magna</i>	eastern meadowlark	C		X	X	c	c	c	c	
<i>Tachycineta bicolor</i>	tree swallow					c		c	c	
<i>Thryothorus ludovicianus</i>	Carolina wren			X	X	c	c	c	c	
<i>Tiaris bicolor</i>	black-faced grassquit					*	*	*		
<i>Toxostoma rufum</i>	brown thrasher					u	*	u	u	
<i>Tringa flavipes</i>	lesser yellowlegs					c	u	c	c	
<i>Tringa melanoleuca</i>	greater yellowlegs					c	u	c	c	
<i>Tringa solitaria</i>	solitary sandpiper					u		u	r	X
<i>Troglodytes aedon</i>	house wren					c		c	c	
<i>Turdus migratorius</i>	American robin					u	*	u	u	

Species	Common Name	Federal Status	State of Florida Status	Breeding in Everglades National Park	Breeding in West Preferred Corridor Area ¹	Spring	Summer	Fall	Winter	Reported Florida Utility Injury or Mortality
<i>Tyrannus melancholicus</i>	tropical kingbird					*			*	
<i>Tyrannus tyrannus</i>	eastern kingbird			X	X	c	c	c	r	
<i>Tyrannus verticalis</i>	western kingbird					u		u	u	
<i>Tyto alba</i>	barn owl	C		X	X	u	u	u	u	X
<i>Vermivora celata</i>	orange-crowned warbler					u		u	u	
<i>Vermivora chrysoptera</i>	golden-winged warbler					r		r		
<i>Vermivora peregrina</i>	Tennessee warbler					u		u	*	
<i>Vermivora pinus</i>	blue-winged warbler					r		r	r	
<i>Vermivora ruficapilla</i>	Nashville warbler					r		r	*	
<i>Vireo altiloquus</i>	black-whiskered vireo	C		X	X	c	c	c	*	
<i>Vireo bellii</i>	Bell's vireo					*			*	
<i>Vireo crassirostris</i>	thick-billed vireo								*	
<i>Vireo flavifrons</i>	yellow-throated vireo					u		u	u	
<i>Vireo griseus</i>	white-eyed vireo			X	X	c	c	c	c	
<i>Vireo olivaceus</i>	red-eyed vireo					c		c	*	

Species	Common Name	Federal Status	State of Florida Status	Breeding in Everglades National Park	Breeding in West Preferred Corridor Area ¹	Spring	Summer	Fall	Winter	Reported Florida Utility Injury or Mortality
<i>Vireo philadelphicus</i>	Philadelphia vireo							*		
<i>Vireo solitarius</i>	blue-headed vireo					u		u	u	
<i>Wilsonia citrina</i>	hooded warbler					u		u	*	
<i>Wilsonia pusilla</i>	Wilson's warbler					r		r	r	
<i>Zenaida asiatica</i>	white-winged dove					r	r	r	r	
<i>Zenaida macroura</i>	mourning dove			X	X	c	c	c	c	
<i>Zonotrichia albicollis</i>	white-throated sparrow					*		*	r	
<i>Zonotrichia leucophrys</i>	white-crowned sparrow							r	*	

¹West Preferred Corridor Area refers to any locations within the proposed West Preferred Corridor in Everglades National Park or within a three-mile radius.

(E = endangered, T = threatened, C = U.S. Fish and Wildlife Service designated nongame migratory species concern, SSC = state of Florida-designated species of special concern) Seasons: Spring (March 1 - May 31), Summer (June 1 - July 31), Fall (August 1 - November 15), Winter (November 16 - April 30). Abundance: c = commonly observed in Everglades National Park (seen 50% or more of the time), u = uncommonly observed in Everglades National Park (seen less than 50% of the time), r = rarely observed in Everglades National Park (seen less than 25% of the time), * = fewer than 10 records in Everglades National Park.

Table 2. Numbers of wading bird nests (also includes anhingas) recorded from surveys conducted at the Tamiami colonies, Grossman Ridge West Colony, in Everglades National Park and the 3B Mud East Colony in Water Conservation Area-3B.

[Data sources: Cook and Kobza, 2009; Cook and Kobza, 2008; Cook and Herring, 2007; Cook and Call, 2006; Cook and Call, 2005; Crozier and Cook, 2004; Crozier and Gawlik, 2003; Gawlik, 2002-1997]

Species/Bird Group and Survey Years	Tamiami East 1	Tamiami East 2	Tamiami West	Grossman Ridge West	3B Mud East
wood storks 1997	0	0	220	0	0
other aquatic nesting birds 1997	70 (GE)	0	150 (GE), 50 (CE)	30 (GE)	95 (GE), 5 (BC)
wood storks 1998	0	0	0	0	0
other aquatic nesting birds 1998	57 (GE)	0	250 (GE)	80 (GE)	100 (GE)
wood storks 1999	0	0	75	0	0
other aquatic nesting birds 1999	41 (GE)	0	400 (GE), 6 (LB), 8 (TH), 10 (BC), 15 (SE), 150 (WI), 35 (CE)	150 (GE)	6 (GB), 10 (AN), 130 (GE)
wood Storks 2000	0	0	1,347	0	0
other aquatic nesting birds 2000	40 (GE)	0	35 (GE), 15 (TH), 2 (BC), 150 (SE), 20 (WI), 30 (CE)	250 (GE), TH (+), BC (+)	177 (GE), 1 (GB), 1 (LB), 9 (TH), 40 (AN)
wood storks 2001	0	0	1,400	0	0
other aquatic nesting birds 2001	0	0	200 (GE), 350 (SE), 100 (WI), 60 (BC)	0	150 (GE)
wood storks 2002	0	0	450	0	0
other aquatic nesting birds 2002	35 (GE)	0	200 (GE), 400 (WI), SE (+), CE (+), TH (+), LB (+)	60 (GE)	270 (GE)
wood storks 2003	0	0	400	0	0

Species/Bird Group and Survey Years	Tamiami East 1	Tamiami East 2	Tamiami West	Grossman Ridge West	3B Mud East
other aquatic nesting birds 2003	20 (GE)	0	200 (GE), 150 (WI), 250 (SE), 400 (CE), 3 (TH), 1 (RS), 4 (BC), 14 (UW)	35 (GE)	505 (GE), 3 (GB), 84 (TH), 5 (BC), 10 (LB), 122 (WI), 4 (YC), 6 (AN)
wood storks 2004	0	0	50	0	130
other aquatic nesting birds 2004	20 (GE)	15 (GE)	175 (GE), 50 (CE), TH (+), BC (+)	150 (GE), 50 (CE), TH (+), BC (+)	350 (GE), 1,153 (WI), 53 (AN), 5 (GB), 141 (TH), 190 (BC), 45 (SE), 65 (LB)
wood storks 2005	0	0	110	0	20
other aquatic nesting birds 2005	8 (GE)	3 (GE)	75 (GE), 500 (WI), SE (+), TH (+), BC (+)	60 (GE)	480 (GE), 30 (AN), 10 (TH)
wood storks 2006	0	0	400	0	15
other aquatic nesting birds 2006	35 (GE)	15 (GE)	200(GE), 600 (WI), SE (+), TH (+), LB (+), BC (+)	130 (GE), 120 (CE), BC (+)	256 (GE), 203 (WI), 200 (SE)
wood storks 2007	0	0	75	0	0
other aquatic nesting birds 2007	0	8 (GE)	60 (GE), 400 (WI)	40 (GE)	0
wood storks 2008	0	0	0	0	0
other aquatic nesting birds 2008	0	0	0	0	0
wood storks 2009	10	20	1,300	60	7
other aquatic nesting birds 2009	35 (GE)	15 (GE)	500 (GE), 5,000 (WI), SE (+), 300 (TH), LB (+), GB (+), 800 BC	75 (GE), SE (+)	324 (GE)

Code abbreviations: anhinga (AN), black-crowned night heron (BC), cattle egret (CE), great blue heron (GB), great egret (GE), little blue heron (LB), roseate spoonbill (RS), snowy egret (SE), tricolored heron (TH), unidentified small wading bird (US), unknown small white wader (UW), yellow-crowned night heron (YC), white ibis (WI), + = Species present and nesting but could not determine nest numbers.

Table 3. Avian injury and mortality reported at the Levee-Midway Transmission Power Line March–July 1996 and February–July, 1997.

[Data source: Deng, 1998]

Species	Common Name	Date	Quantity Injured/Killed	Injury/Mortality Cause
<i>Ardea alba</i>	great egret	3/19/1996	1 - mortality	power line collision
<i>Ardea alba</i>	great egret	6		
<i>Ardea alba</i>	great egret	5/1996	1 - mortality	power line collision
<i>Bubulcus ibis</i>	cattle egret	6/28/1996	1 - injury	power line collision - unable to fly
<i>Mycteria americana</i>	wood stork	3/25/1996	1 - mortality	power line collision
<i>Mycteria americana</i>	wood stork	6		
<i>Mycteria americana</i>	wood stork	4/7/1996	1 - mortality	power line/vehicle collision
<i>Pandion haliaetus</i>	osprey	5/15/1996	1 - injured	power line collision - broken wing
<i>Pandion haliaetus</i>	osprey	6		
<i>Quiscalus spp.</i>	grackle	5/7/1996	1 - mortality	power line collision

Table 4. Avian mortality reported from Florida Power and Light transmission structures in Florida from January 1, 2005, through May 21, 2010.

[Data source: Florida Power and Light unpublished data, 2010]

Species	Common Name	Date	Quantity Killed	Mortality Cause
<i>Ardea herodias</i>	great blue heron	2/25/2005	1	ground wire power line collision
<i>Ardea herodias</i>	great blue heron	4/12/2005	1	ground wire power line collision
<i>Ardea herodias</i>	great blue heron	3/9/2010	1	ground wire power line collision
<i>Coragyps atratus</i>	black vulture	2/27/2005	1	electrocution – suspect streamer
<i>Coragyps atratus</i>	black vulture	12/19/2005	1	electrocution – suspect streamer
unknown	vulture	6/20/2007	1	electrocution – suspect streamer
unknown	vulture	11/12/2009	1	electrocution – suspect streamer
unknown	vulture	4/4/2009	1	electrocution – suspect streamer
<i>Grus canadensis pratensis</i>	sandhill crane	1/27/2008	1	power line collision
<i>Haliaeetus leucocephalus</i>	bald eagle (juvenile)	3/31/2006	1	power line collision
<i>Pandion haliaetus</i>	osprey	11/30/2005	1	power line collision
<i>Pandion haliaetus</i>	osprey	12/13/2007	1	power line collision
<i>Pelecanus erythrorhynchos</i>	white pelican	4/10/2010	4	ground wire power line collision
<i>Pelecanus erythrorhynchos</i>	white pelican	5/3/2010	1	ground wire power line collision
unknown	blue heron	9/26/2007	1	ground wire power line collision
unknown	seagull	1/16/2007	1	power line collision

Table 5. Avian injury and mortality risk factors that exist within the West Preferred Corridor and adjacent habitats (approximately 3-mile radius).

Risk Factors Identified in the Literature	EXISTS
Abundance and diversity of avian species that produce streamers	X
Power line crosses major wetland system	X
Power line crosses foraging, roosting, or nesting sites	X
Power line crosses migratory bird route	X
Abundance and diversity of roosting and/or breeding/nesting birds	X
Abundance and diversity of juvenile avian species	X
Abundance and diversity of nocturnal and crepuscular species	X
Abundance and diversity of birds with morphology susceptible to power line collisions (i.e., high wing loading ratio – such as wading birds and waterfowl species)	X
Presence of federal- and state-listed threatened/endangered avian species and special status species	X

Table 6. Distance traveled to foraging sites at the L-67 Colony in WCA-3 in 1989.

[Data source: Bancroft et al., 1994]

Species	Mean distance (\pm 1 standard deviation)
great egret	1.9 \pm 2.1
white ibis	7.5 \pm 6.0
snowy egret	18.9 \pm 9.9
little blue heron	2.8 \pm 1.9
tricolored heron	3.5 \pm 3.7

